

H Type Carburetter

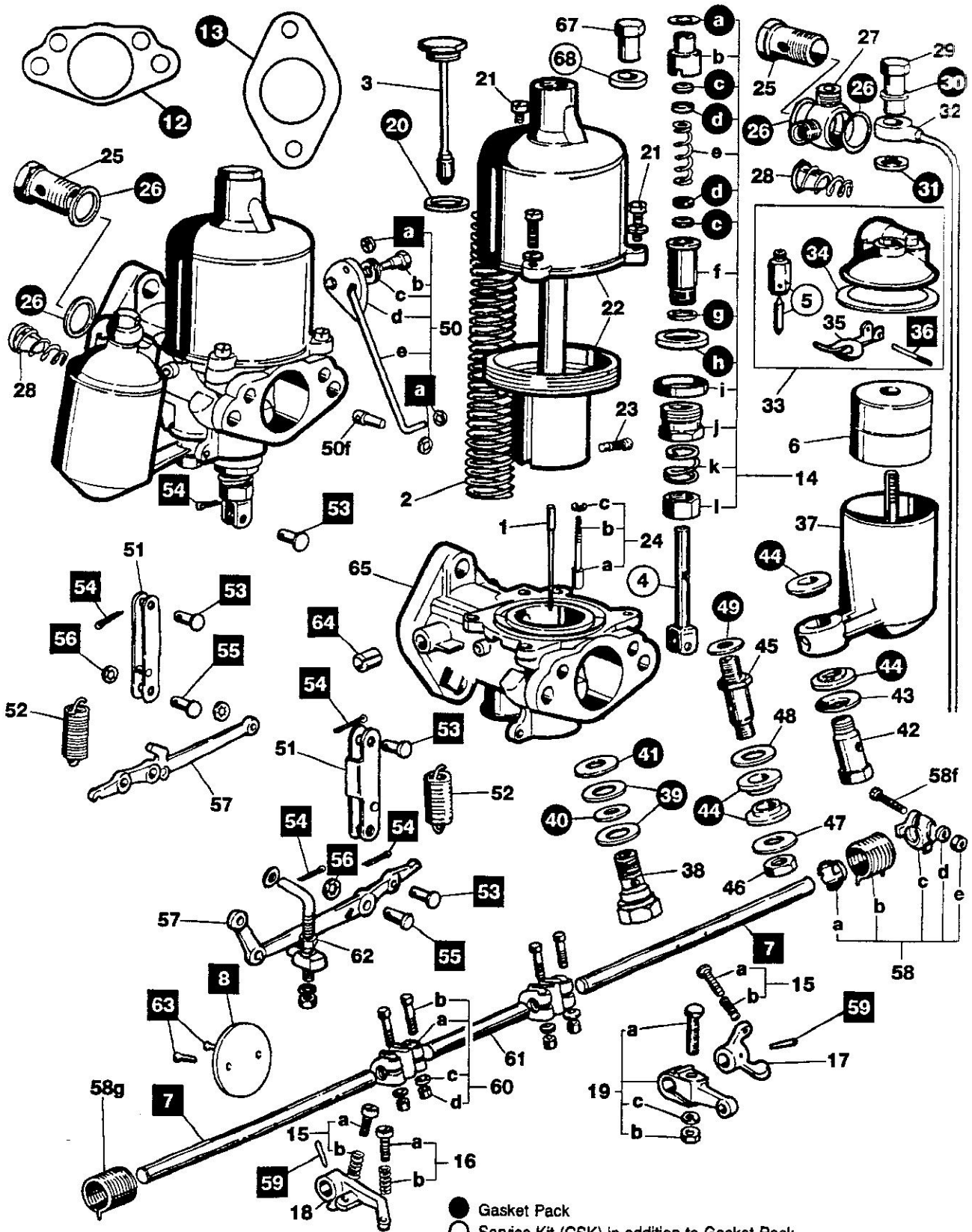

- Gasket Pack
- Service Kit (CSK) in addition to Gasket Pack
- Rebuild Kit (CRK) in addition to CSK

Each kit contains enough components to service one carburetter.
 The pair of carburetters illustrated are H4 but most H types are similar.
Note: Refer to page 6 for help identifying the carburetter's specification.
 Refer to page 8 for details of carburetter sundries kits.

