

## PIC-1 Pedal Board & Swell Shoe Midi Encoder

**Pedal Contact Input.** The Pedal contact inputs consist of either 32 Molex header pins that mate with Molex KK-100 series terminals and connector housing. In place of the Molex connector, the PIC-1 is available with a 34 terminal ribbon cable connector.

Pedal contacts are wired directly to each corresponding input on the PIC-1. C1 pedal contact is connected to C1, the first input on the card. C#1 to the second, D to the third, D# to the fourth and so on to pedal contact 32. The contact Common side should be all common connect and connected to a GROUND lead that can be connected to one of the two GROUND terminals on the DC Power Terminal Block.

The inputs are a PULL TO GROUND or Zero volts to enable a midi note. C1 will generate MIDI NOTE 36.

**Power Supply.** The PIC-1 is designed to operate from a Regulated DC power supply that can range from 7 to 18 Volts. The NES-15-12 is recommended with an output of 12 VDC regulated.

The Green Power Terminal Block located on the PIC-1 has four terminals, Two for GROUND connections and Two for Plus VDC. There is an onboard 5 volt regulator for powering the CPU and related circuitry. A diode from the power block plus terminals to the 5 volt regulator will prevent damage to the card in case the input power wires are accidentally reversed.

**MIDI IN, MIDI OUT Jacks.** There are two type on MIDI jack provided, the standard DIN 5 terminal midi jacks. For installations with limited space, Molex three terminal Jacks. Refer to Figure 4 for information on assembling Molex midi plugs.

**RED and Green LED's** There are two LED indicators on the PIC-1. The Green LED indicates that DC power is ON to the card. The RED LED will flash when midi data is being sent due to a Pedal Key being played.

**NOTE:** The Red Activity LED will not flash when a Swell Shoe is moved, due to a different type of midi message.

### Swell Shoe DIP Switch's and Inputs.

- **Swell Shoe Connections.** Located between the Swell Shoe DIP switch and the Power Connector is a Six terminal connector strip labeled - 1, 2, 3, 4 and +. Refer to Fig 3 for the wiring configuration. Each shoe will require a 5000 ohm Liner Taper potentiometer, the High Side terminal is wired to the PLUS terminal, the low side of the pot to the GROUND terminal of the six pin connector P-1. The wiper of each pot will connect to terminals labeled 1, 2, 3 and 4, depending on how many swell shoes are installed. The mating connector is a SIX Terminal Molex KK-100 series.
- **Swell Shoe DIP Switch** For each terminal that has a pot connected, the corresponding DIP switch will be put in the OFF position. For example, if a pot is connected to Terminal 1, switch 1 will be set to OFF and switch's 2, 3 and 4 will be set to ON. When testing the swell shoe operation, midi note 0 should be seen for closed and note 128 for full open. If the note range is reversed, reverse the wires on Pin 1 and 6 on the connector.

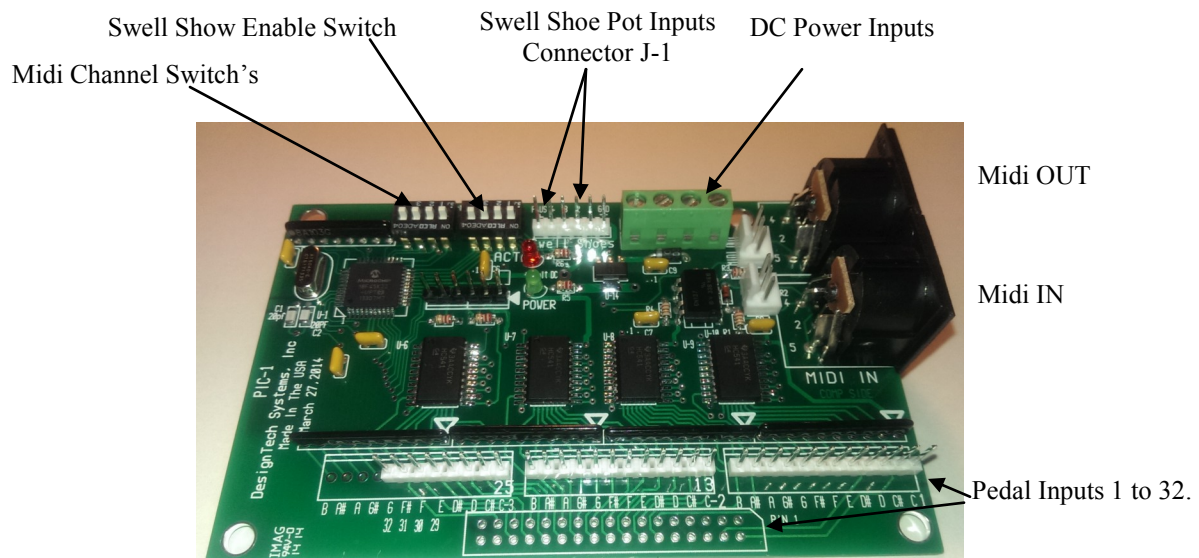

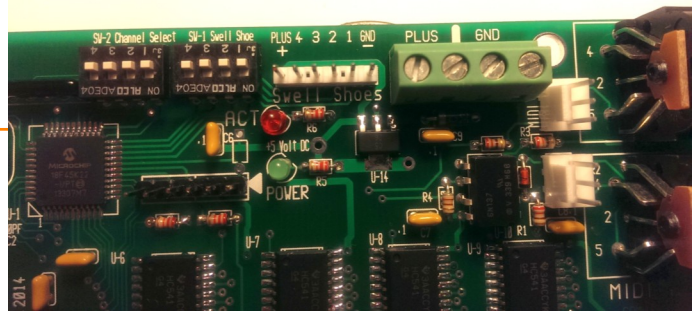
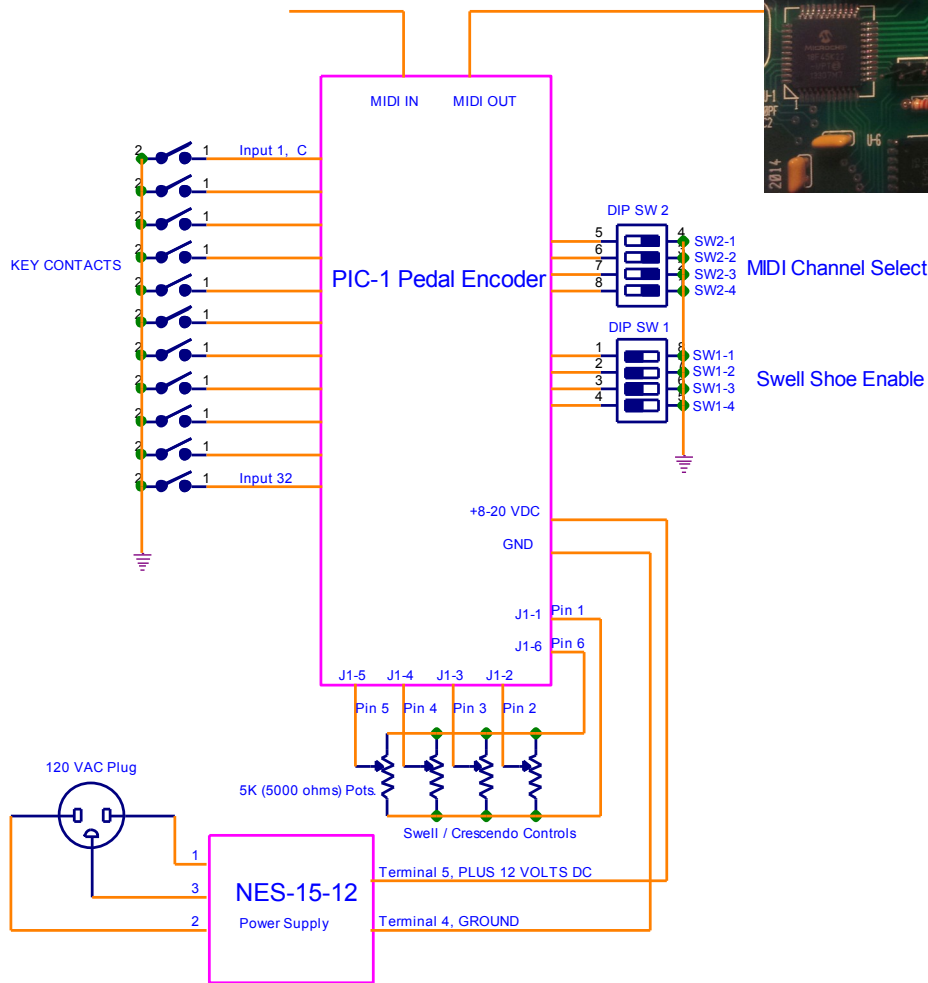

Midi Channel Switch Setting.  
Switch # 1,2,3,4

Channel	Sw2-1	Sw2-2	Sw2-3	Sw2-4
1	X			
2		X		
3	X	X		
4			X	
5	X		X	
6		X	X	
7	X	X	X	
8				X
9	X			X
10		X		X
11	X	X		X
12			X	X
13	X		X	X
14		X	X	X
15	X	X	X	X
16				
	1	2	4	8

### MIDI Cable Assembly

Located next to each MIDI Jack are two three pin Molex connectors which are also Midi IN, Midi OUT connections. Cable assemblies can easily be made using the enclosed three terminal Molex connectors and a desired length of TWO CONDUCTOR SHILDED cable.

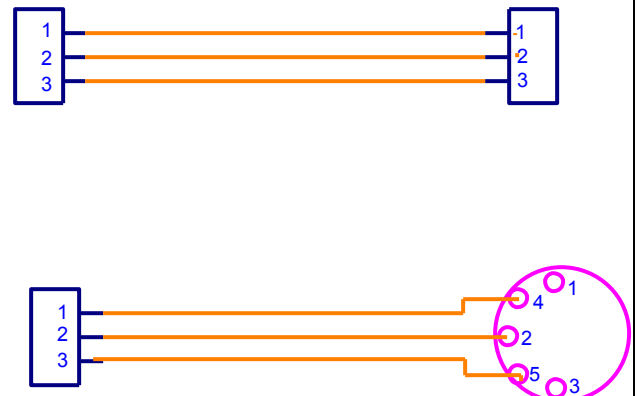

FIG. 4