

ANCHOR NOTES WORKSHEET

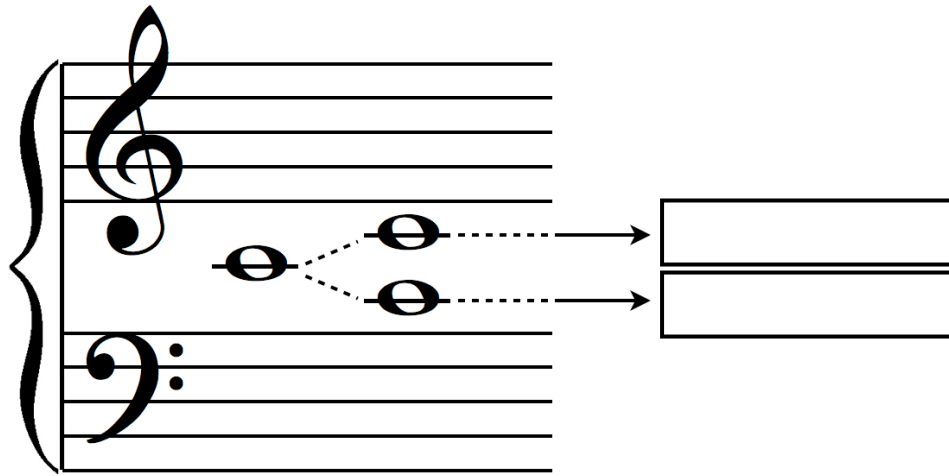

A grand staff with treble and bass clefs. The treble clef has a whole note on the second line (D4). The bass clef has a whole note on the second space (D3). Dotted lines connect the two notes, with arrows pointing to two empty rectangular boxes for labeling.

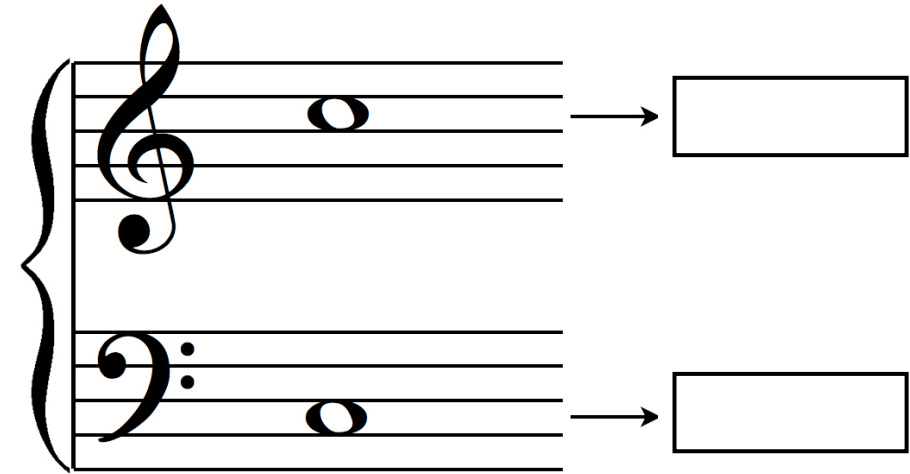

A grand staff with treble and bass clefs. The treble clef has a whole note on the first space (C4). The bass clef has a whole note on the first space (C3). Arrows point from each note to an empty rectangular box for labeling.

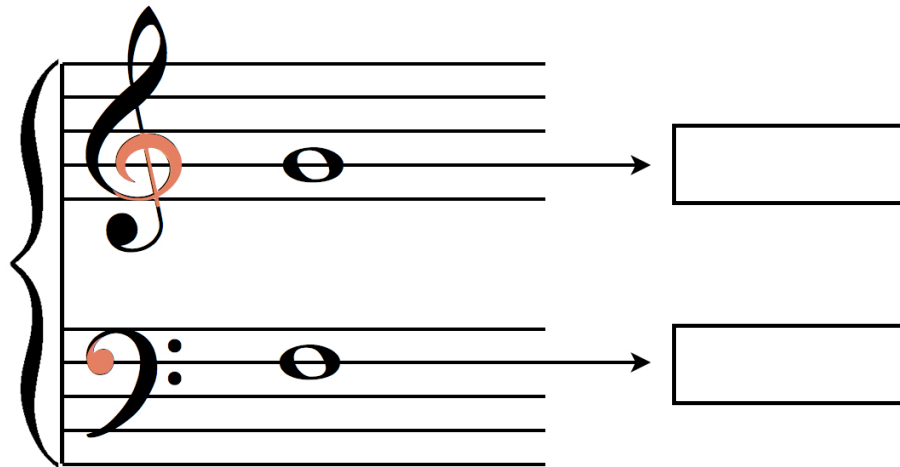

A grand staff with treble and bass clefs. The treble clef has a whole note on the first space (C4), and the bass clef has a whole note on the first space (C3). The notes are highlighted in red. Arrows point from each note to an empty rectangular box for labeling.

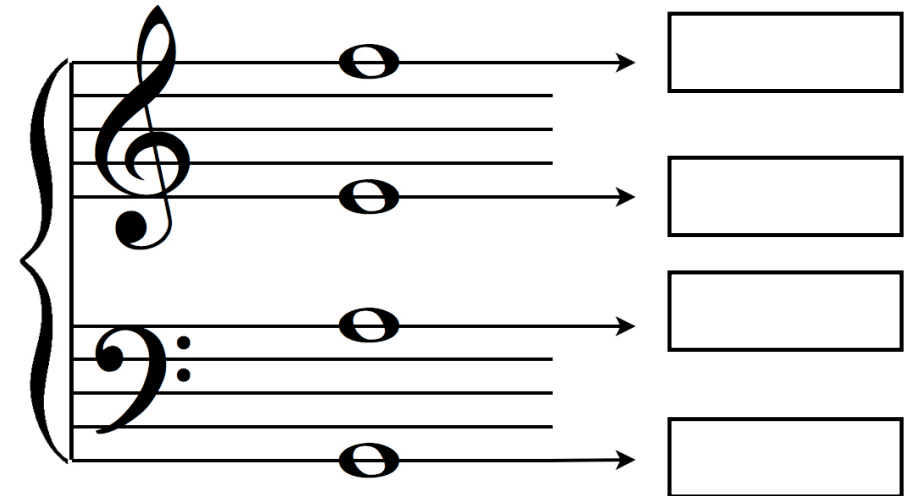

A grand staff with treble and bass clefs. The treble clef has whole notes on the first space (C4) and the second line (D4). The bass clef has whole notes on the first space (C3) and the second space (D3). Arrows point from each note to an empty rectangular box for labeling.