



by Rioned

ANDY GUEST
JETTERS

V-PACK 4 SERIES

The V-Pack 4 Series is the most powerful machine in our standard range. It is designed to clear almost any blockage with ease.

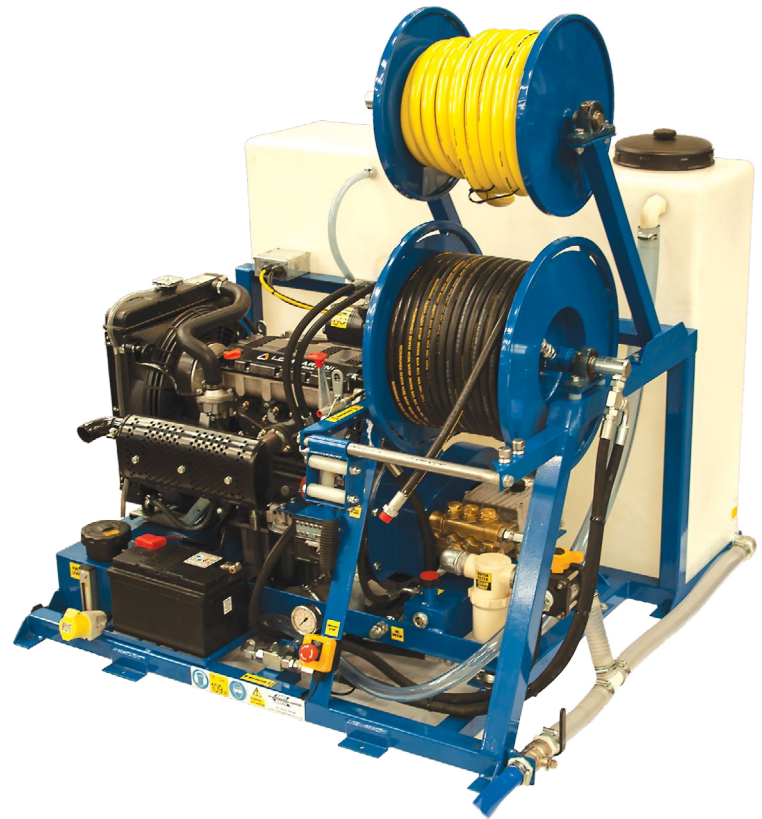

Despite its high output the V-Pack 4 Series is surprisingly compact and lightweight, sharing its design with the smaller three series. The unit has been specially designed by our engineers for increased performance levels without the need for a larger frame.

Suitable for sewers and drains up to \varnothing 350mm

The V-Pack 4 Series is ideally suited to all domestic and commercial work and light industrial applications. With pressures of over 4000psi and flow rates of up to 120LPM, it is the ideal choice for the professional operator who demands the highest level of performance.

The V-Pack 4 Series is also available in 'Stack' configuration for use in dual purpose vehicles and we supply a comprehensive range of accessories for all applications.

Andy Guest Jetters produce their high-pressure jetting machines in accordance with machine directives (2006/42/EC), in conformance with the regulations of the following EEC directives: 2004/108/EC and the following harmonized European standards have been applied: NEN-EN-ISO 12100-1, NEN-EN-ISO 12100-2, NEN-EN-ISO 13850, NEN-EN-ISO 13857, NEN-EN-349, EN 60204-1.

Andy Guest Jetters Ltd

Unit 11, Riparian Way
The Crossings Business Park
Cross Hills, Keighley
West Yorkshire BD20 7BW

Tel: + 44 (0) 3300 240 404
www.andyguestjettters.co.uk
info@andyguestjettters.co.uk

V-PACK 4 SERIES

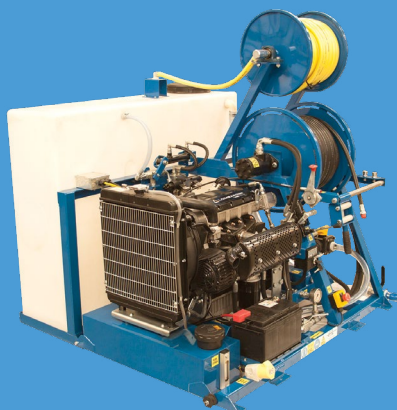

UPGRADES + OPTIONS

- ▶ Tank Capacity Upgrade (500, 650 or 800 Litres)
- ▶ Full Engine & Pump Cover
- ▶ Speck HP Pump Upgrade
- ▶ 5 Channel Radio Remote Control
- ▶ Hard Wired Foot Pedal
- ▶ Hose Guidance
- ▶ Run Dry Protection
- ▶ Lightweight Jetting Hose
- ▶ Leader Hose
- ▶ Mini Hose Kit
- ▶ Safety Lance
- ▶ Dry Shut Lance
- ▶ Nozzle Kit
- ▶ Hydraulic Root Cutter
- ▶ Warthog
- ▶ Chain Flail Kit
- ▶ Suction Ventury
- ▶ Hot Water System Upgrade

TECHNICAL SPECIFICATION

Pipework Diameter	< 350mm
Performance	3625psi @ 13GPM (250BAR @ 60LPM)*
Std Water Tank Capacity:	400 Litres (88 Gallon)
Engine	4 Cylinder Diesel (Lombardini Kohler LDW2204)
Engine Power	44HP (32kW)
HP Pump Type	Triplex Plunger Pump
Engine Cooling	Water Cooled
Run Dry Protection	Not Included (Optional)
Frost Protection	Anti-Freeze Valve
HP Reel	Hydraulic Drive
Hose Guidance	Not Included (Optional)
Hose	90 Metres ½" Jetting Hose (300ft)
Reel Arrangement	Fixed Hose Reel
Filling Hose	25 Metres
Control Box	Yes
Pressure Relief System	Unloader Valve
Remote Control	5 Channel Radio Remote System or Foot Pedal
Construction	Compact Mild Steel Construction, Shot Blasted, Zinc Primed & Powder Coated
Accessories Included	2 Standard Nozzles, User Manual
Approx. Dry Weight	565KG
Approx. Max Weight	965KG (with standard 400 litre water tank)
Dimensions (mm)	1350 D x 1300 W x 1350 H (with standard water tank)
Fuel Tank Capacity	20 Litres
Base Vehicle Suitability	Ford Transit Transit, Vauxhall Movano, Mercedes Benz Sprinter, VW Crafter, Renault Master, Peugeot Boxer
Warranty	12 Months (Terms and conditions apply)

*Other capacities are available

DIMENSIONS + CONFIGURATION

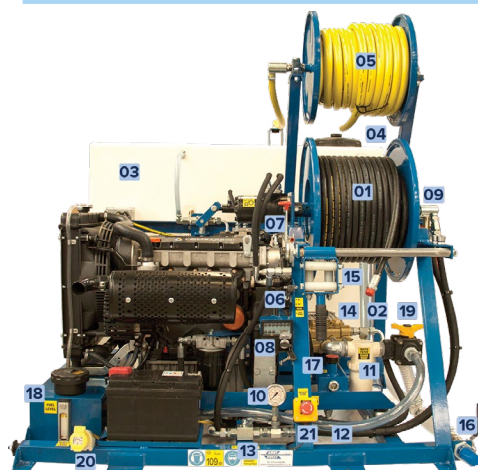
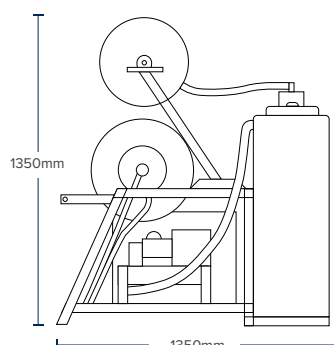
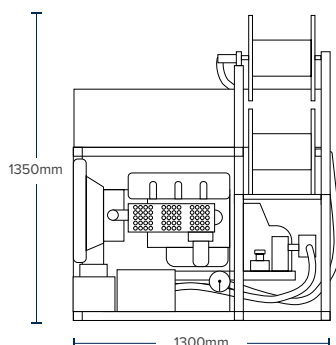

Andy Guest Jetters Ltd

Tel: + 44 (0) 3300 240 404

www.andyguestjettters.co.uk

info@andyguestjettters.co.uk

01	High Pressure Hose & Reel	12	Anti-freeze suction pipe
02	Overflow pipe	13	Selector Valve
03	Water tank	14	Pump
04	Supply opening water tank	15	Hose guidance adapter
05	Inlet hose on reel	16	Drain
06	Hydraulic reel control	17	Hydraulic Oil tank
07	Throttle	18	Fuel tank with opening
08	Control box	19	Anti-freeze valve
09	Rotary joint	20	Hardwire remote socket
10	Pressure gauge	21	Emergency Stop
11	Water filter		