

The cylinder heads are fitted with inserted valve seats and valve guides.

Each cylinder head is attached to the cylinder block by means of eighteen studs. Tighten the stud nuts with the special torque-indicating wrench. Its application makes controllable the torque that must range from 7.3 to 7.8 kgf·m. The stud nuts may be also tightened with the special cylinder head nut wrench (17x19) available in the vehicle SPTA set. The nuts must be driven smoothly and only by one hand. The nuts should be tightened on cold engine in two or three stages following the order shown in Fig. 3. Before tightening the stud nuts, drain coolant from the cooling system and loosen the intake manifold nuts.

Prior to removing the rocker RH cover, proceed as follows:

- (a) loosen the compressor fastening by turning back its three nuts by 5 to 7 mm;
- (b) remove the adjusting plate bolt;
- (c) remove the compressor drive belt;
- (d) shift the compressor forward.

To enable access to the cylinder head nuts, unscrew the rocker shaft support nuts, lift or remove the shaft jointly with the rockers, and remove the shield of

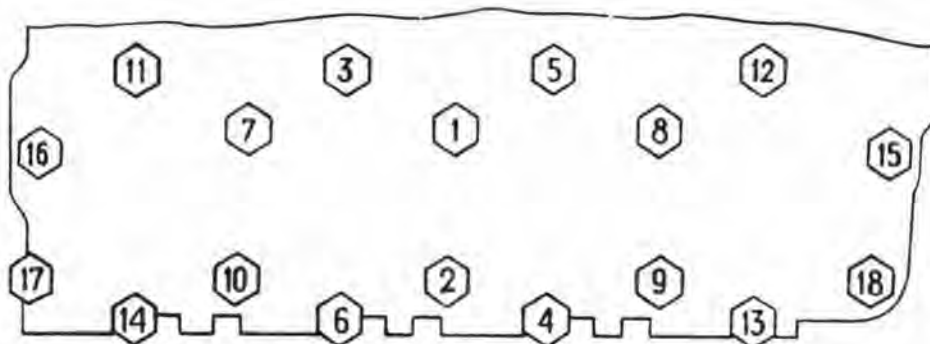

FIG. 3. CYLINDER HEAD NUTS TIGHTENING ORDER

the spark plugs. It is advisable to take the valve rods out of their seats to avoid accidental bending. After tightening up the cylinder head nuts, reinstall and secure all the removed parts. This done, adjust the clearances between the valves and the rockers. The first tightening of the cylinder head nuts on a new vehicle must be done after 1000 km of run, the second after 3000 km, and all the successive ones in the course of every other Preventive Maintenance No. 2, i.e. every 6000 km of run.

Tightening of intake manifold nuts as well as its reinstallation must be done as carefully as possible, to prevent coolant from getting into lubricant.

Prior to installation, check condition of mating surfaces of the intake manifold, cylinder head and cylinder block, and that of the gaskets. At first, screw the nuts so as to press the gaskets only slightly, and then tighten them securely in two or three stages starting from the middle of the intake manifold alternately on the LH and RH cylinder heads by applying moderate hand effort. Keep in mind that the rubber gasket makes one feel that the nuts are not completely tightened. Hence, tighten the nuts so that the gasket is compressed by 1 to 1.5 mm.

#### Valve Timing Mechanism

The camshaft is driven by two gears: a steel one fitted on the crankshaft and a textolite one fitted on the camshaft.

All gears in the transfer are spur.

Shifting of gears is effected by sliding of gear 6 along the primary shaft and bringing it in mesh with the secondary shaft gear (high range gear) or gear 19 (low range gear).

The front axle is engaged by sliding of gear 18 along the splines of counter-shaft 22 and bringing it in mesh with gear 17.

Sliding of the gears is effected through the forks attached to the selector bars. The selector bars are connected with the front axle and range control levers through the system of rods, levers and shafts.

The retainers are arranged in the transfer case boss over the selector bars.

The transfer gear-shift mechanism is fitted with a lock that prevents transfer into the low range when the front axle is disengaged, or disengagement of the front axle when the low range gear is engaged.

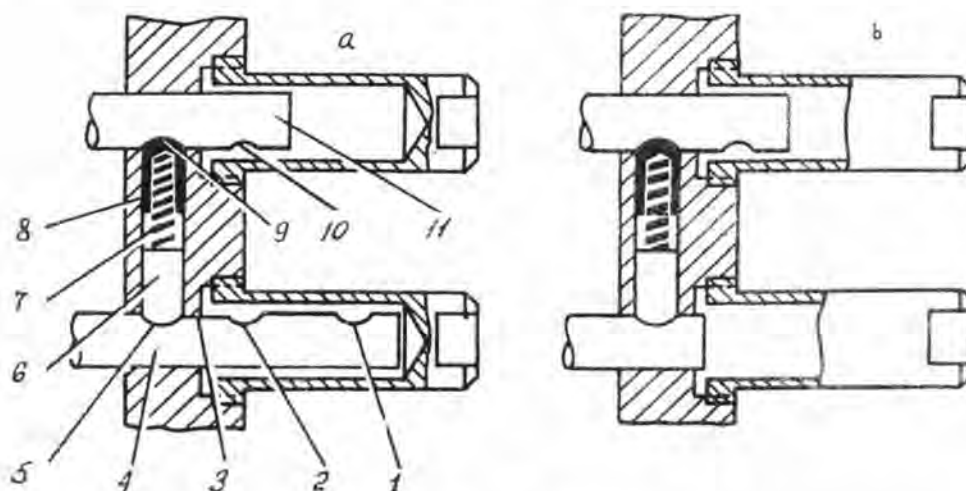

FIG. 34. TRANSFER INTERLOCKING DEVICE

1, 2, 5 - recesses on gear selector bar; 3 - flat between recesses; 4 - gear selector bar; 6, 8 - plungers; 7 - spring; 9, 10 - recesses on front axle selector bar; 11 - front axle selector bar

Construction of the transfer lock is shown in Fig. 34. Two hollow plungers 6 and 8 are installed in the transfer case opening between selector bars 4 and 11. Due to retracting spring 7, the plungers enter the recesses made in the selector bars and thus retain them in certain position.

The range selector bar has three recesses 5, 2 and 1. Middle recess 2 serves to retain the bar in the neutral position, while the two extreme recesses serve for retain the bar in the selected position. Front axle selector bar 11 has two recesses 9 and 10; the first of them serves to retain the front axle driving gear in the engaged position, and the second, in the disengaged position. Recess 9 is approximately twice as deep as recess 10.

With the selector bars arranged as shown in Fig. 34, a, the front axle and the high range gear are engaged. To engage the low range gear, selector bar 4 should be shifted leftwards until recess 1 is engaged with plunger 6 (Fig. 34, b). With the selector bar in this position (i.e. with the low range gear engaged), the clearance between lock plungers 6 and 8 will be less than recess 9. Therefore, the plunger cannot get fully out of recess 9 when selector bar 11 moves leftwards. Thus disengagement of the front axle in the low range becomes impossible. The low range gear cannot be engaged either unless the front axle is engaged.

The transfer is controlled by means of two control levers (Fig. 35). The right one is used for engagement of the front axle. It has two positions: forward (when the front axle is engaged) and rearward (when the front axle is disengaged). The

2. Hoist the vehicle hull simultaneously with two jacks up to the height of the trestle.

3. Place the trestle under the hull and lower the latter on the trestle.

4. Hoist the other end of the vehicle hull with the jacks and place it on the other trestle.

5. Use the jacks and the wooden bars to further hoist alternately the front and rear of the hull while placing boards between the hull and trestles until the wheels are clear of ground. Lower the auxiliary wheels.

The vehicle is removed from the trestles in the reverse order.

When putting the vehicle on and removing it from the trestles, observe the following safety rules:

(a) install jacks and wooden bars underneath properly and reliably; observe the safety precautions;

(b) Hoist and lower the vehicle hull with the jacks smoothly and evenly.

#### TYRE PRESSURE CONTROL SYSTEM

The vehicle is equipped with a tyre pressure control system that ensures control by the driver of the tyre inflation pressure when the vehicle is at halt or in motion depending on the type of the road surface and speed of movement. The system also permits monitoring of the pressure in each tyre.

Reducing the tyre pressure when moving over soft ground decreases the specific ground pressure and increases the vehicle cross-country ability. In case of a bullet puncture or other minor damage to the inner tube, the tyre pressure control system enables further movement of the vehicle without immediate replacement of the damaged wheel since the compressor makes up for air leakage from the inner tube.

The tyre pressure control system consists of compressor 10 (Fig. 55), pressure regulator 9, two air bottles 5, non-return valve 11, air reducer 1, tyre cock unit 3, tyre pressure gauge 2, air bottles pressure gauge 12, air cocks in the wheels, pipelines and hoses.

The tyre pressure control system operates as follows. Air from compressor 10 is delivered into air bottles 5 and therefrom, through the pipeline fitted via non-return valve 11, into air reducer 1. The air reducer communicates with the wheel tyre inner tubes through tyre cock unit 3, and pipelines. The tyre pressure is automatically maintained in compliance with the position of the pointer in the air reducer scale.

When the air reducer knob is turned counterclockwise air is admitted in the wheel tyre inner tubes (inflation). When the knob is turned in the opposite direction, air is released from the tyres.

The air compressor (Fig. 56) is of a piston, non-direct-flow, double-cylinder, single-stage type. The compressor cylinder block and cylinder head are cooled by liquid supplied from the vehicle engine cooling system.

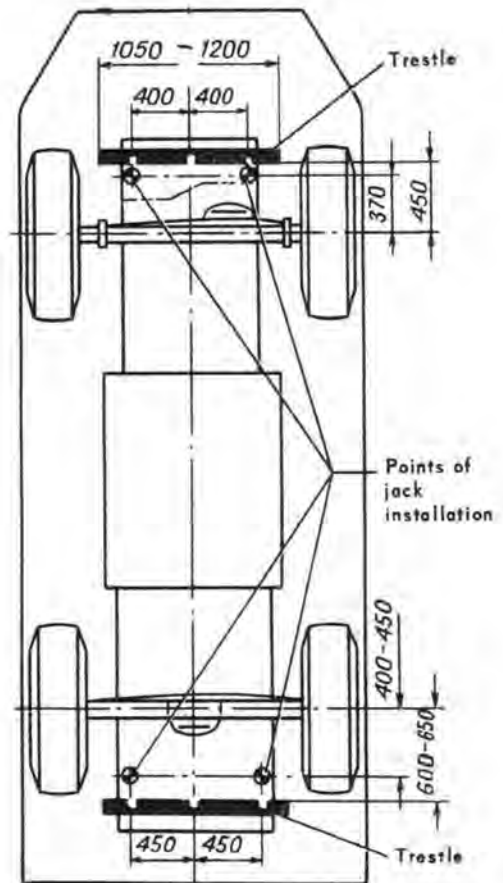

FIG. 54. POSITION OF JACKS AND TRESTLES WHEN JACKING-UP БРДМ-2 VEHICLE

## PERSONNEL HEATER AND WINDSHIELD DEFROSTER

The vehicle is equipped with plenum-type personnel heater 4 (Fig. 114) installed inside the vehicle, to the left of the driver's seat. The heater blower fitted on the shaft of a two-speed electric motor circulates air through heat exchanger 2.

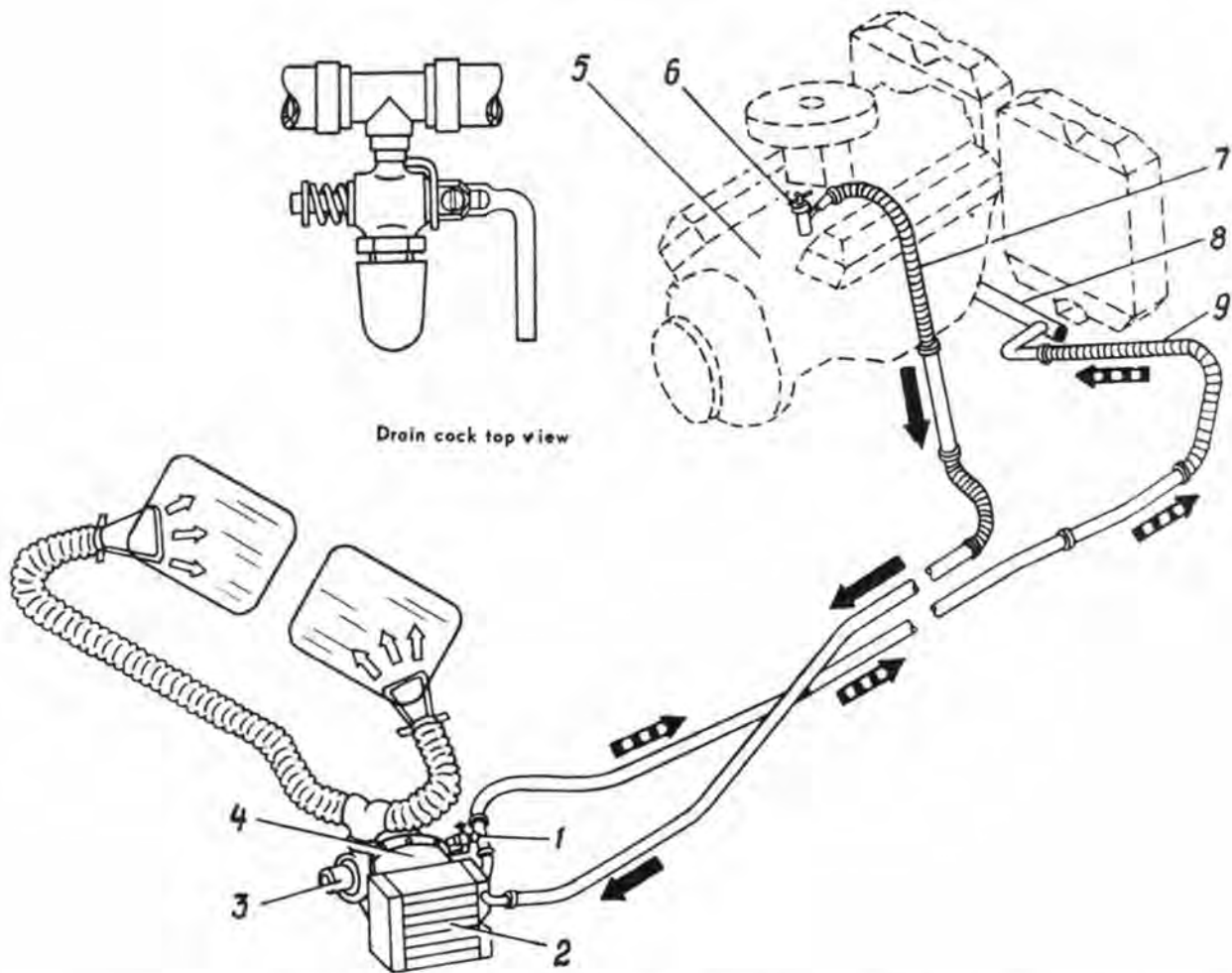

FIG. 114. VEHICLE HEATING AND WINDSHIELD DEFROSTER SYSTEM

1 - drain cock; 2 - heat exchanger; 3 - windshield defroster electric motor; 4 - heater; 5 - engine; 6 - shutoff cock; 7 - delivery hose; 8 - pipe running from heat exchanger to water pump; 9 - outlet hose

The heated coolant enters the heat exchanger from the engine cooling system through delivery hose 7. Flow of coolant is regulated by shutoff cock 6 located on the engine intake manifold.

If the coolant is water, the cock must be opened only after the engine is warmed up to prevent entry of cold water in the heat exchanger of the personnel heater and its freezing in it. A special motor-driven blower draws the heated air from the heater through corrugated hoses and delivers it to the vehicle windshields for defrosting.

The blower is cut in/out by a switch located on the instrument panel. For efficient operation, the personnel heater should be cut in only after the engine is warmed so that the temperature of coolant is as high as 80°C.

In summer, with shutoff cock 6 closed, the heater blower may be used for circulating the air inside the vehicle.

When draining coolant from the cooling system, first open heater drain cock 1 located on the front left-side wheel bay.

To ensure normal operation of the personnel heater and to prevent the blower blades from rubbing against the spokes of the electric motor flange and rods of the