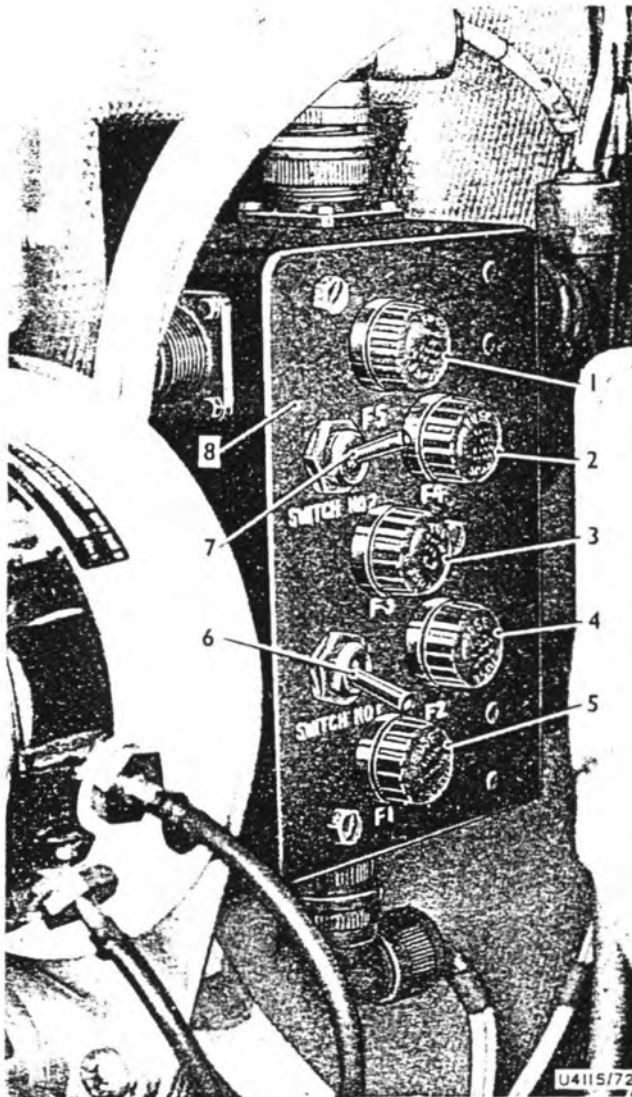

Fig 2 Overall dimensions

(Amdt.10)



- 1 Fuse F5 (fuses F2 and F4)
- 2 Fuse F4 (3 interior lights)
- 3 Fuse F3 (smoke grenade dischargers)
- 4 Fuse F2 (3 interior lights)
- 5 Fuse F1 (driver's screen wiper)
- 6 Switch No.1 controlling smoke dischargers switchbox
- 7 Switch No.2 controlling interior lights
- 8 Auxiliary junction box

Fig II Auxiliary junction box

Interior lights blackout switch  
(Fig 23(9))

Power tool unit warning light

- ... At the top left corner of the rear door on the inner side. Provided for use when blackout conditions are in force.
- ... Located at the top right corner of the unit (Fig 12(11)) facing the rear of the vehicle. Only operative when using power tool equipment. Shows if the generator "cuts out" due to overheating of unit.

- (3) Pull out the carburetter starting control (25). Slacken the locknut, then unscrew and remove the knob and locknut.
- (4) On early type access plates, turn the tongue locks a quarter turn so that the saw cuts indicate that the tongues are free. Remove the plate by pulling it outward and downward from the top taking care not to damage the starting control rod.
- (5) On later type access plates, release the four clamp plates sealing the joint of the two sections, turn the tongue locks securing the upper section and lift the section away. Turn the tongue locks securing the lower section and lift the lower section away taking care not to damage the starting control rod.
- (6) To replace the plate, proceed in the reverse sequence to that for removing.

### Commander's cupola

46. The cupola is rotatable through 360 deg to allow all round vision for the commander and full use of the M.G.

47. Three periscopes (Fig 20(6)) are mounted side by side on the cupola ring with the M.G. pintle mounting bracket (1) welded to the housing for the periscopes. A window is mounted on the periscope guard to cover the object glass of the left periscope. The window has a wiper operated by a flexible cable and return spring. To operate the wiper, pull down the handle of the flexible cable then release it. The wiper arm returns under the action of the return spring. The hinged door in the top of the cupola is spring assisted for opening and is held closed by two rotatable catches (Fig 16(2)). The catches can only be operated from inside the vehicle. A stop bracket and spring catch retains the door in an open position.

48. The cupola can be locked against rotation by three clamps (1) disposed equidistantly round the cupola ring. By turning down the clamp handles from horizontal to vertical, the cupola can be held from further rotation to hold a field of view.

### Commander's seat

49. The seat (Fig 21) is attached to the vehicle side plate below the cupola. It is adjustable for height and can be stowed to allow free passage to and from the driver's compartment.

50. To adjust the seat for height, slacken the hand wheel (4) on the seat support (3) lift or lower the seat to the required position then re-tighten the hand wheel.

51. The seat and backrest (1) can be moved to facilitate access to the driver's compartment from the personnel compartment. To move the seat, lift the backrest and lower it backwards, then lift the seat at the opposite side to the hinge (2).

### Mortar hatch

52. The mortar hatch is the large circular hatch in the personnel compartment roof. When open, the door segments fold back clear of the hatchway. The weight of the segments is counterbalanced by torsion bars (Fig 22(3) and (9)). The door is secured when closed by six rotatable catches (Fig 13(4)), two on each outer segment and two on an inner segment which overlaps and holds the other inner segment.

## PART 3 - SERVICING

123. Detailed servicing includes a visual inspection of the vehicle and equipment to ensure they are in good condition, correctly assembled and secure.

124. All lubricating points, whether nipples or surfaces and the surrounding areas must be cleaned before applying lubricant. All excess lubricant should be wiped off after working the joints to ensure that inaccessible parts are adequately greased.

125. Before replenishing fuels, lubricants etc., the area surrounding the filler caps should be thoroughly cleaned.

### FIRE FIGHTING EQUIPMENT

#### TO CHECK A PORTABLE FIRE EXTINGUISHER

126. (1) Remove the extinguisher from its bracket and examine it for damage.
- (2) Check the pressure indicator by trying to move the disc (Fig 36(2)) or applying thumb pressure to the cap (10). If the disc is loose or the cap pressed in from convex to concave form, the extinguisher should be discarded and a replacement obtained.
- (3) Check that the discharge nozzle (8) or (14) is clear.

**Note:** The extinguishers are sealed and cannot be dismantled for further examination.

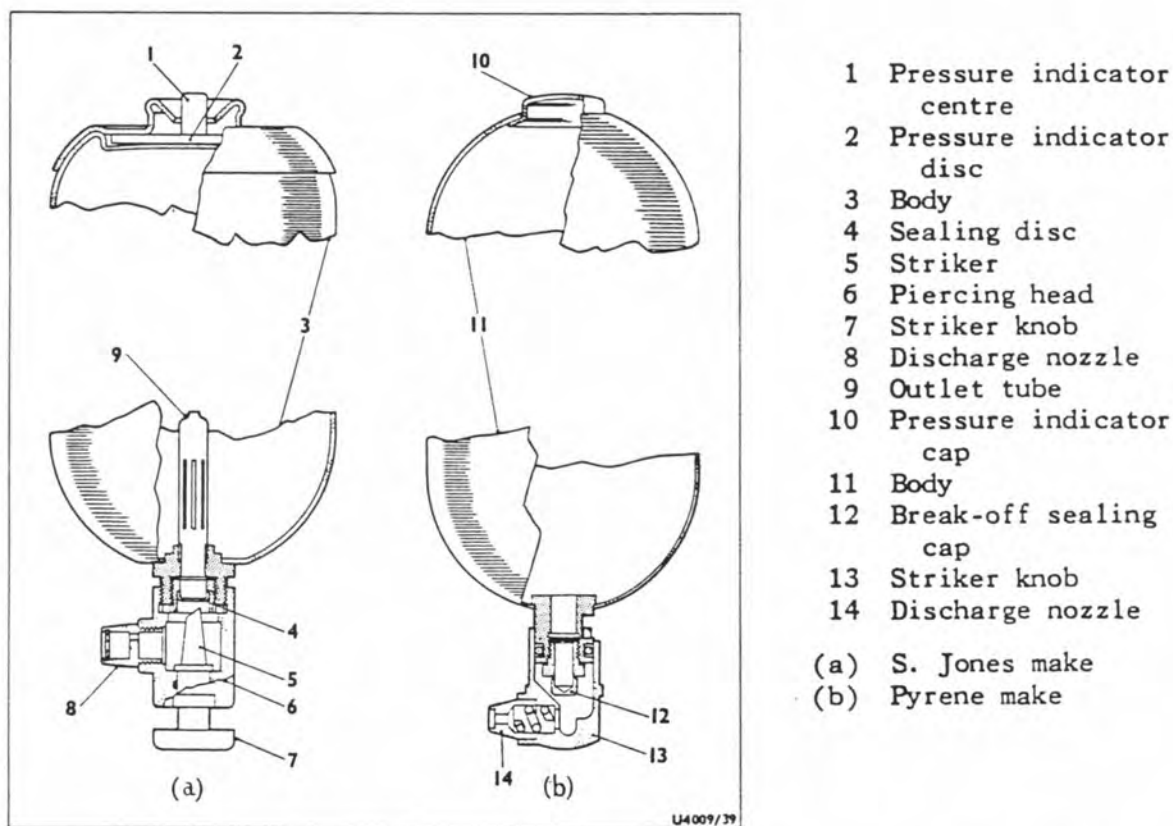

Fig 36 Wet water and chlorobromomethane fire extinguishers - expendable types

## STEERING LINKAGE LUBRICATION

167. The steering lever cross-shafts are lubricated through four lubricating nipples, the three forward nipples (Fig 53(3), (4) and (5)) on the battery of five located in the driver's compartment to the right of the steering levers. The fourth nipple is located on the main cross-shaft sleeve and is accessible when the steering unit access plate is open.

168. Each steering unit brake operating shaft (Fig 38(6)) has a lubricating nipple (8) on the inner end face. The fork (4) and (7) connecting pins must be oil can lubricated.

## FINAL DRIVE

### TO CHECK THE FINAL DRIVE OIL LEVEL

169. With the vehicle standing level, proceed with each final drive as follows:-

- (1) Remove the filler plug (Fig 54(1)) from the top of the elbow on the casing.
- (2) Check that the oil level is up to the bend of the elbow. Add oil if necessary to bring the level correct. Allow sufficient time for the oil to find its true level.
- (3) Replace the filler plug.

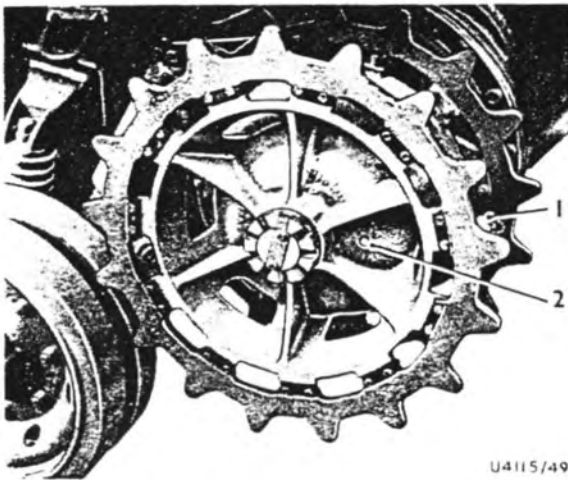

- 1 Filler plug
- 2 Lubrication nipple

Fig 54 Final drive

U4115/49

### TO CHANGE THE FINAL DRIVE OIL

170. This operation must be carried out after the vehicle has been run and the oil is warm.