

6. The forward part of the vehicle is divided to form a driver's compartment on the right-hand side and a compartment for an ammunition stowage bin and water tank on the left-hand side. The rear of the driver's compartment is open to permit access to the fighting compartment.

7. The fighting compartment occupies the centre of the vehicle and accommodates the commander, gunner and operator. The batteries are housed beneath the compartment floor at the front.

The power operated turret contains the main armament and auxiliary weapons. The wireless set is mounted in a recess at the rear of the turret.

The fighting compartment is separated from the engine compartment by a rear bulkhead, which is fitted with a large access plate to facilitate engine maintenance.

8. The engine is a Meteor Mk 4B or 4B/1 liquid-cooled gasoline engine developing 650 b.h.p. at 2,550 r.p.m.

Air intakes for cooling are provided in the cover on top of the engine compartment. Air is drawn in by two fans driven from the rear of the engine.

The fuel tanks are mounted in the hull on each side of the engine. The engine oil tank is situated at the rear of the right-hand fuel tank.

9. A charging set engine is mounted in the left-hand front corner of the engine compartment. This engine is used for driving the generator and ventilating fan. The

engine is operated independently of the main engine, except that the cooling and fuel systems are interconnected. The controls for this engine are mounted on the fighting compartment bulkhead.

10. Power from the main engine is transmitted to the rear through the clutch to the gearbox. This gearbox, in addition to providing five forward speeds and two reverse, incorporates two steering units, which are mounted at each side of the gearbox. From each steering unit the drive passes to the final drive and sprocket.

11. Two swivelling radiators are mounted above the gearbox. Air is forced through the radiators by the engine fans, and expelled through louvres at the rear of the vehicle.

12. The hull is supported on six suspension units, each having two pairs of road wheels and three concentric springs. The road wheels are connected to the suspension units by axle arms. The front and rear suspension units incorporate shock absorbers which are linked to the axle arms.

Steel idler wheels are fitted at the front of the vehicle, one on each side. The idler wheel axle assemblies incorporate the track adjusting device. The tracks are driven by sprockets at the rear of the vehicle, the top run being supported on four double and two single guide rollers.

Additional protection for the sides of the hull is provided by six detachable skirting plates, three on each side.

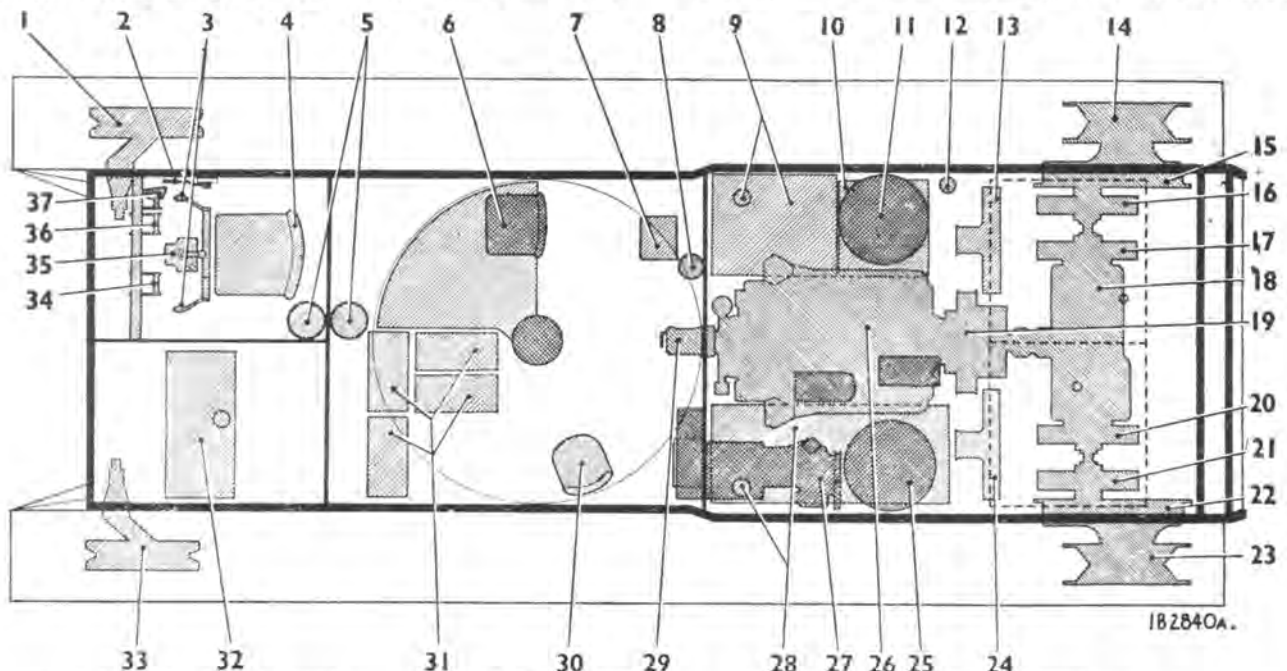

- |                                 |                         |                                  |
|---------------------------------|-------------------------|----------------------------------|
| 1. R.H. track adjuster assembly | 14. R.H. sprocket       | 26. Main engine                  |
| 2. Handbrake lever              | 15. R.H. final drive    | 27. Charging set engine          |
| 3. Steering levers              | 16. R.H. main brake     | 28. L.H. fuel tank and filler    |
| 4. Driver's seat                | 17. R.H. steering brake | 29. Starter motor                |
| 5. CO <sub>2</sub> cylinders    | 18. Gearbox             | 30. Operator's seat              |
| 6. Gunner's seat                | 19. Clutch              | 31. Batteries                    |
| 7. Commander's seat             | 20. L.H. steering brake | 32. Drinking water tank          |
| 8. Charging set air cleaner     | 21. L.H. main brake     | 33. L.H. track adjuster assembly |
| 9. R.H. fuel tank and filler    | 22. L.H. final drive    | 34. Clutch pedal                 |
| 10. Main engine oil tank        | 23. L.H. sprocket       | 35. Gear lever                   |
| 11. R.H. air cleaner            | 24. L.H. fan            | 36. Brake pedal                  |
| 12. Main engine oil filler      | 25. L.H. air cleaner    | 37. Accelerator pedal            |
| 13. R.H. fan                    |                         |                                  |

Fig. 2—Layout of main components.

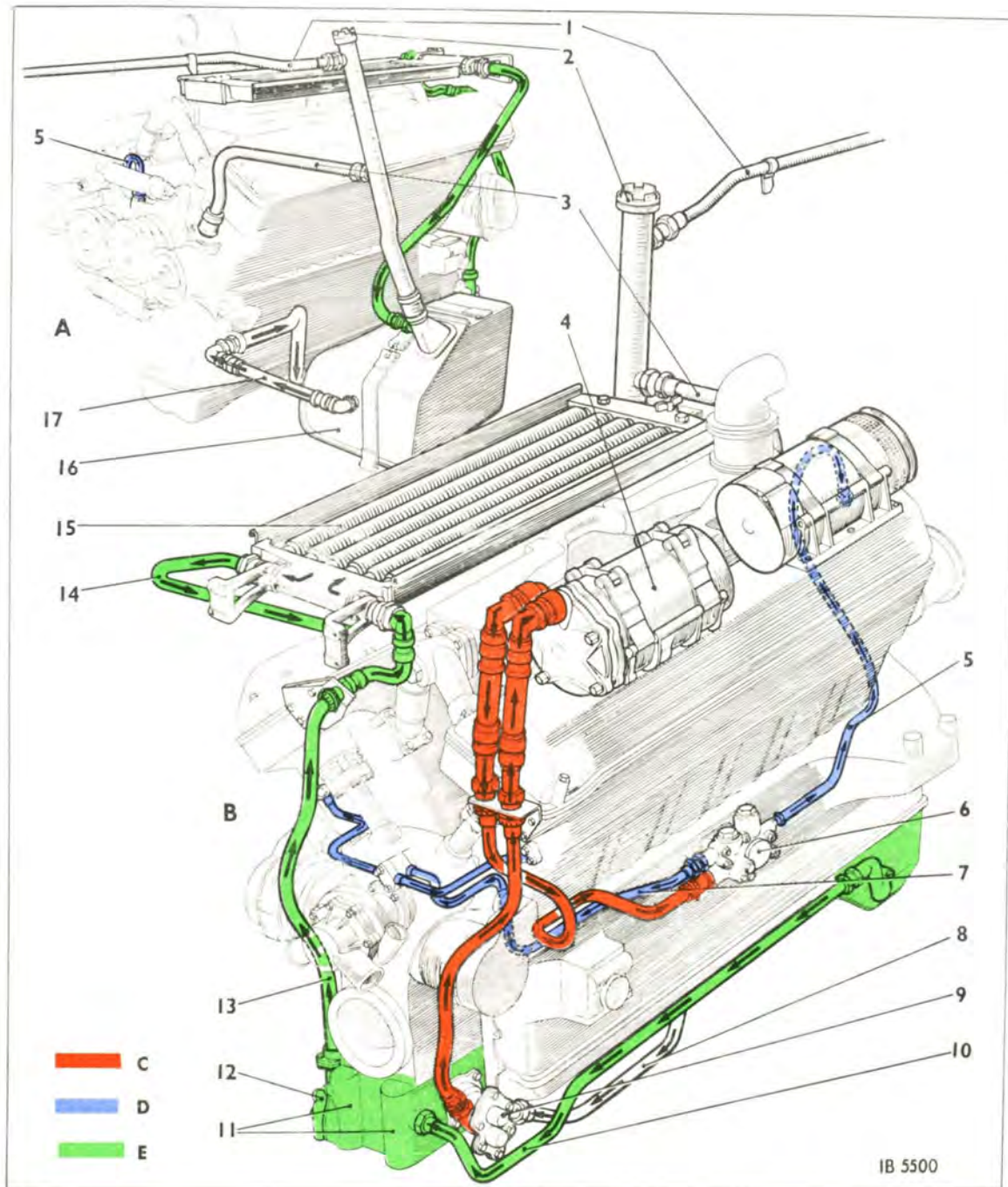

1. Breather pipe to atmosphere
2. Filler cap
3. Breather pipe—engine to filler pipe
4. Pressure filter
5. Low-pressure feed to fan drive gears
6. Pressure relief valve unit
7. Low-pressure feed to wheelcase and valve gear
8. Delivery pipe from oil tank

9. Pressure pump
10. Return pipe from rear sump to scavenge pump
11. Scavenge filter housings
12. Scavenge pumps
13. Return pipe from scavenge pump to oil cooler

14. Return pipe to oil tank
15. Oil cooler
16. Engine oil tank
17. Pipe to pressure pump
- A. Right-hand rear of system
- B. Left-hand front of system
- C. High-pressure
- D. Low-pressure
- E. Scavenge

Fig. 13—Engine lubrication system

163. Two press-button switches, see Fig. 30 (9), marked MAG, L.H. and MAG, R.H. are located on the L.H. side of the control panel mounted in the centre of the fighting compartment bulkhead.

By depressing either switch, the respective ignition circuit can be switched off and so in turn, each circuit can be tested for correct operation. The MAG, R.H. button cuts out the "exhaust" plugs and a test is therefore made on the "inlet" plugs. The MAG, L.H. button cuts out the "inlet" plugs and a test is therefore made of the "exhaust" plugs.

In an emergency, the crew commander can stop the engine by depressing both buttons simultaneously.

#### Mag-reset switch

163A. This switch is located in the coolant level indicator box, para 107B, and is used in emergency only on the instruction of the crew commander, para 108A.

#### 164. To test the ignition circuits:

When the engine has warmed up, increase the speed to 2,000 r.p.m. and operate each ignition test switch in turn.

Check exhaust note on each ignition system. Report if running is uneven on either system or an excessive drop in r.p.m. occurs.

### SERVICING THE IGNITION SYSTEM

#### Sparking plugs (Fig. 25)

165. The sparking plugs must be cleaned and gaps reset by an electrician every 1,000 miles.

#### 166. To remove, clean and replace the inlet plugs:

(a) Equipment required:—

- |                                   |                            |
|-----------------------------------|----------------------------|
| $\frac{3}{4}$ in. spanner         | $\frac{3}{16}$ in. spanner |
| Crowfoot spanner                  | $\frac{7}{16}$ in. spanner |
| Universal spanner for inlet plugs |                            |
| Rag or waste                      | A.B.413                    |
| Tommy bar                         |                            |

(b) Method:—

- (i) Open the engine covers ( $\frac{3}{4}$  in. spanner)
- (ii) Traverse the turret to 9 o'clock approximately and raise the oil cooler. The turret must not be traversed while the oil cooler is in the raised position.

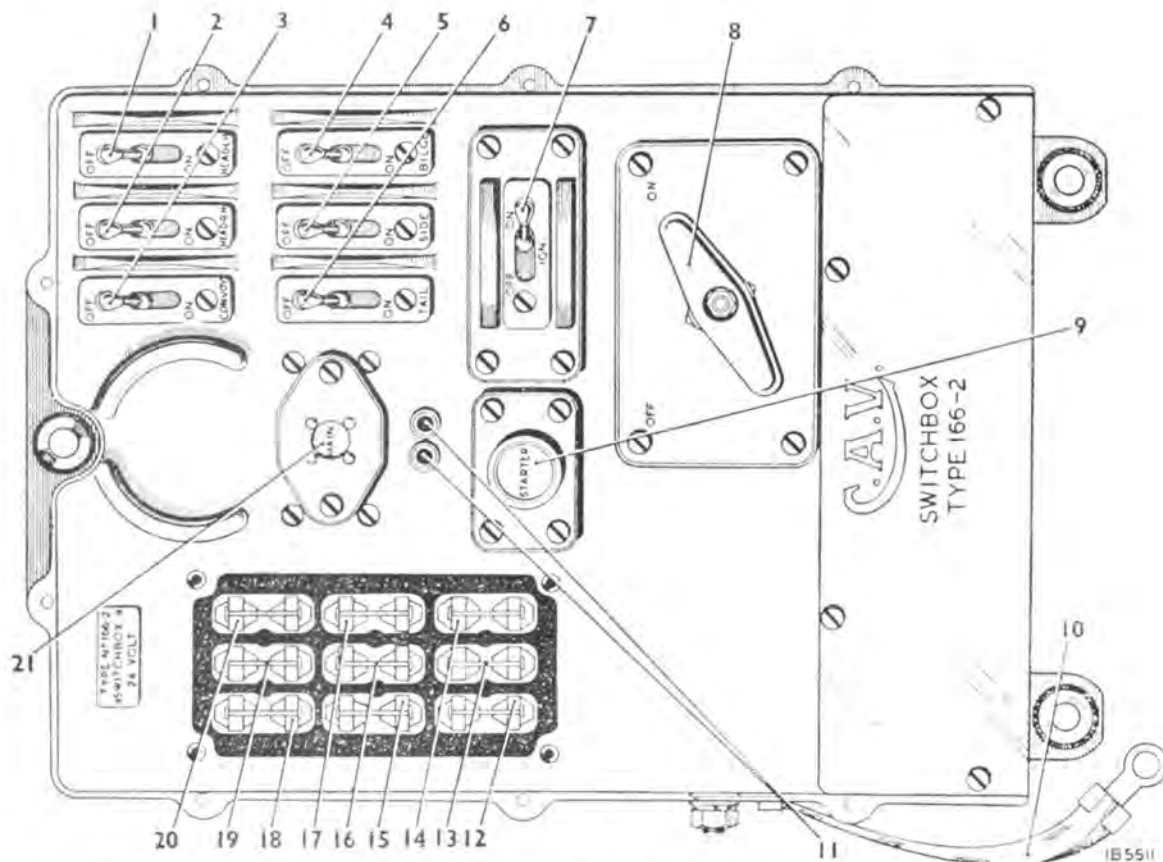

- |   |                               |                                |
|---|-------------------------------|--------------------------------|
| 1. Lower headlamp switch                        | 8. Battery master switch      | 15. Fuse D                     |
| 2. Upper headlamp switch                        | 9. Main engine starter button | 16. Fuse E                     |
| 3. Convoy lamp switch                           | 10. Earthing braid            | 17. Fuse F                     |
| 4. Bilge pump and Mono-trailer fuel pump switch | 11. Inspection lamp socket    | 18. Fuse A                     |
| 5. Side lamp switch                             | 12. Fuse G                    | 19. Fuse B                     |
| 6. Tail lamp switch                             | 13. Fuse H                    | 20. Fuse C                     |
| 7. Ignition switch                              | 14. Fuse J                    | 21. Main warning light (amber) |

Fig. 24—Driver's switchboard—fuse cover removed.

## 15—ENGINE CLUTCH

234. The clutch is of the triple dry plate type. The operating mechanism is located on the engine side of the clutch.

### OPERATION OF CONTROLS

#### Clutch pedal

235. The linkage, see Fig. 40 (18) between the clutch pedal and the clutch withdrawal mechanism is entirely mechanical. When the clutch pedal is depressed, movement is transmitted to the cross-shaft (Fig. 37) which carries the clutch withdrawal fork. The withdrawal fork forces the withdrawal bearing towards the clutch, causing the release levers to withdraw the pressure plate against the pressure of the clutch springs.

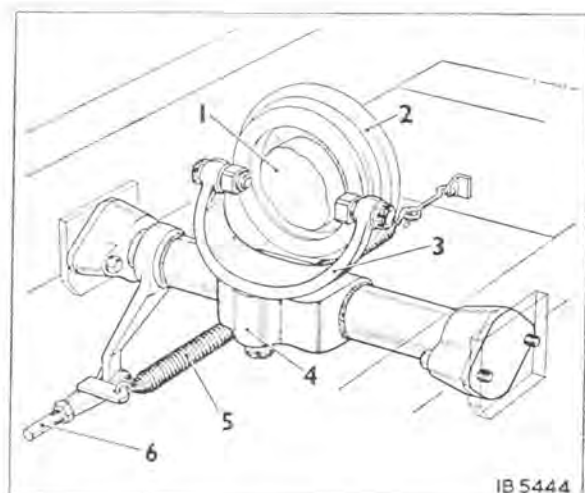

1. Clutch input shaft
2. Clutch withdrawal race
3. Clutch withdrawal fork
4. Operating fork (free to swivel in housing)
5. Pull-off spring
6. Clutch control linkage

Fig. 37—Clutch withdrawal mechanism—late vehicles.

When the pedal is released, the clutch springs and pressure plate exert clamping pressure on the intermediate plates and the driven plates, causing the release levers and withdrawal bearing to be returned to their original position. At the same time the clutch linkage return spring, located behind the clutch, exerts a pull on the linkage causing the pedal to be returned against its stop.

The clutch pedal should be operated with the instep of the boot not the ball of the foot.

### SERVICING THE CLUTCH

#### Clutch pedal free travel

236. The clutch pedal should have  $1\frac{1}{2}$  in. to 2 in. free travel in order to give between  $\frac{1}{8}$  in. and  $\frac{3}{16}$  in. clearance

between the ends of the withdrawal fork and the withdrawal bearing. This clearance diminishes as the clutch linings wear, and care must be taken to readjust the linkage before all the clearance is taken up, as at this stage, clutch slip occurs resulting in serious damage to the clutch assembly.

#### 237. To check free travel (daily task):

- (i) Operate the clutch pedal to ensure that the controls are moving freely and that the pedal returns to its stop.
- (ii) Move the pedal forward and check that the amount of free travel is between  $1\frac{1}{2}$  in. and 2 in.

#### 238. To adjust the free travel (Fig. 29):

- (a) Equipment required:—  
 $\frac{7}{16}$  in. spanner
- (b) Method:—
  - (i) Slacken the two locknuts on the long rod (28) connecting the clutch pedal to the relay shaft lever on the left of the driver's seat ( $\frac{7}{16}$  in. spanner).
  - (ii) Rotate the rod in the required direction (clockwise to increase free travel) until the correct free travel is obtained ( $\frac{7}{16}$  in. spanner).
  - (iii) Tighten the locknuts ensuring that the rod does not turn.

#### Clutch withdrawal mechanism

239. On early type vehicles, the clutch withdrawal bearing is lubricated from a remote lubricating nipple located on the top of the fan drive casing and accessible from the engine compartment. The clutch withdrawal fork cross-shaft bearings are provided with lubricators accessible through the clutch access hole see Fig. 9 (9).

Lubricate the withdrawal bearing with one pump of Grease LG-320 (weekly).

**Important:**—Do not over-lubricate as any excess grease may be drawn on to the clutch plates, causing slip. Lubricate the cross-shaft bearings with Grease LG-320 until it exudes from the bearings (every 250 miles). Wipe up any excess grease.

Late type vehicles are fitted with a redesigned clutch withdrawal bearing stirrup-type withdrawal fork and cross-shaft. Two lubricators are fitted to the cross-shaft but no lubrication is required between overhauls (Fig. 37).

#### Clutch relay shaft and clutch control rods

240. The relay shaft on the left-hand of the driver's seat is fitted with a lubricating nipple. Lubricate with Grease LG-320 (every 250 miles).

The clutch control rods should be lubricated with an oil can, OMD-110 (every 500 miles).

## 24-Breaking a Track using an Explosive Charge

that it does not rest on the metal of the container. The largest diameter must be downwards with the knot underneath. Build up the remaining  $\frac{1}{4}$  lb PE3A round the primer and secure it in position with adhesive tape (4).

- (iv) From the result of the safety fuze timing test calculate the length of fuze required. Example - time to walk between the vehicle and cover as described in subpara (b) = 2 minutes 4 seconds; time to burn 1 ft of fuze = 31 seconds. Therefore, length of fuze required in this case =  $\frac{124}{31}$  = 4 ft. Add 6 in. for safety = 4 ft 6 in. Cut two pieces of fuze each to the length calculated and ensure that the ends are square. The cuts should be made with a sharp knife on a hard surface - it is important to make clean cuts. **UNDER NO CIRCUMSTANCES WILL THE LENGTHS OF SAFETY FUZE BE SHORTER THAN 18 in.**
- (v) Inspect the detonators to ensure that the whole length of the cavities are free from sawdust or any other obstruction and remove any foreign matter by gently shaking the detonator. Should this action fail to remove the foreign matter, place the detonator aside for destruction with the charge. **ON NO ACCOUNT WILL A PROBE OF ANY TYPE BE USED IN THE OPEN END OF THE DETONATOR.**
- (vi) The depth of the cavity in a No.27 detonator is never less than 0.8 in. Mark off this distance on each length of safety fuze from one of the straight cut ends. Push this end very gently into the open end of the detonator until the mark is just short of the lip of the cavity. **ON NO ACCOUNT WILL A SCREW MOTION OR FORCE BE USED AS EITHER CAN CAUSE THE DETONATOR TO IGNITE.** Hold the detonator and fuze in this position. Using a Crimpers, Tube Sealing, crimp the detonators (Fig 66(3)) to the fuze (2) near the end where the fuze en-

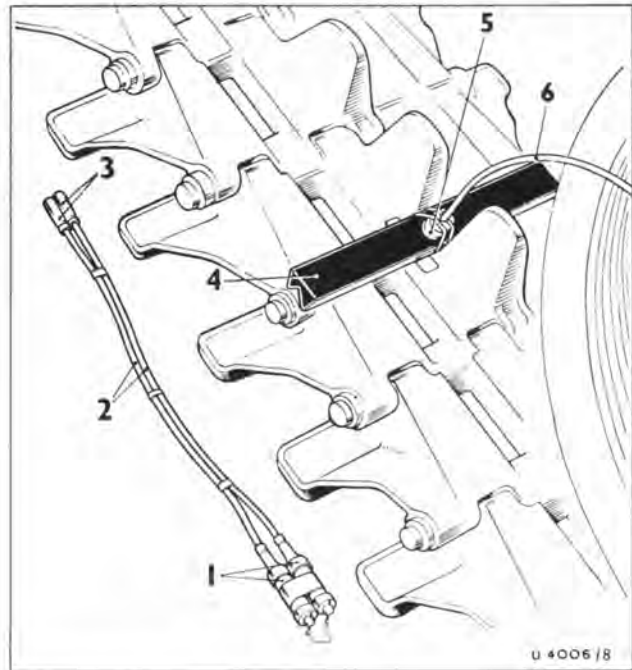

- 1 Igniters, safety fuze, percussion, Mk 3
- 2 No.11 safety fuze
- 3 No.27 detonators
- 4 Container in position along track pin
- 5 1 oz CE primer secured in explosive
- 6 Detonating cord

Fig 66 Container in position and safety fuze assembled

ters the detonators. The detonators **MUST NOT BE CRIMPED NEAR THE CLOSED END.**

- (vii) At the other end of each safety fuze fit an igniter (1). Push the safety fuze into the body until the end reaches the restriction (approximately  $\frac{3}{4}$  of an inch from the end), and, except when using the type of snout which grips the fuze, crimp it into place.
- (viii) Tape the igniters together and keep the safety fuzes together by securing them with adhesive tape.
- (f) The container (4) should now be placed at right angles across the track and secured with its locating tabs in a position midway between the track adjusting wheel and the first road wheel. If it is not possible to place the tray in this position, the tray must be placed midway