

Beginners AM medium wave radio TRF1

Over the years I have built many different radios, and there is something special about listening to a radio you build yourself. Many people choose a radio as their first real project. It's a great idea as it something that can provide hours of entertainment for the builder. Unfortunately finding a circuit that works well and doesn't cost a fortune can be a big problem. The Kanga AM Radio kit gives good performance and is low cost so a double win.

It would make a great first kit that is easy to build and works well without any alignment problems. The board

layout is designed to be a good beginner's project with extra-large solder pads and wide spacing of parts that make it easy to solder. Also this kit is intended to be for educational purposes as well as fun so there is more explanation in these instructions than would normally be found in such a simple kit.

Before we get to the Kit let's look a little about how a radio receiver works. (Very simplistically)

If we could see radio waves we would find them everywhere, the Sky is full of them from local and national radio stations, TV, satellite, mobile phones, 2 way radios. The list would go on and on. All these signals are landing on our receiver at the same time and so we need to be able to select just the one we want. Imaging being in a room full of people all talking at the same time. It would be hard to follow one conversation. We would need to filter out just the one voice we want to hear.

Let's think of it differently. Think of a long flat sheet with small holes at the nearest end, medium holes in the centre and larger holes at the back.

If we took a bag full of mixed ball bearings and rolled them over the sheet the small ones would fall through the first holes. The others would pass over these holes and pass further down the sheet until they found a suitable sized hole and then fall through that. This sheet and its holes will act like a size filter. In our radio circuit we start with a mix of radio signals and we want to filter out just the one we want, the right size or Frequency. Just like the right size hole in the sheet did for the bearings. This is the purpose of the tuned circuit.

The tuned circuit normally is two parts, a fixed inductor (the coil of wire) and a variable capacitor, this as the effect of changing the 'hole' size and so different signals can be selected.

The better the quality of the inductor and capacitor the better defined the 'holes' (Selectivity) are and also these better parts offer less resistance to the wanted signal and let it pass through without losing energy (sensitivity). This makes it easier to filter out just the signal you want. Poor quality parts will not produce such a Sharp hole and nearby signals will also pass through and even the wanted signal will lose some of it energy as it fights its way through making the receiver seem insensitive in use.



Once we have selected the right signal we need to process it to hear the information being transmitted, we are looking at AM radio here (Amplitude Modulation), with these type of signals the transmitter output level is changed in sympathy with the voice or music being transmitted. We will see the signal received also rapidly change in signal level. This variation will if amplified reproduce the original transmitted audio for us to hear.

This signal when received, is in the order of microvolts and it needs to be increase to several volts before we can hear it in our headphones or speaker. In a simple radio such as this kit we are using a radio chip that detects these small changes in signal and amplifiers them to a level that only needs an additional single transistor to boost it to a usable level. This is called a TRF (tuned radio frequency) radio. Most commercial radios use a more complicated arrangement and make a superheterodyne or superhet receiver. This offers higher levels of selectivity and sensitivity but makes the circuit much more complicated. These types of radios need a lot of alignment to get satisfactory results. For our needs the good old TRF method is fine after all the TRF was the original radio receiver used in the early days of radio (1930's) .

The kit here is powered from a single AAA battery so is suitable to be built and used by anyone that can operate a soldering iron safely.

Let's look at the Kit.

The kit uses a TRF radio chip the TA7642. Basically a complete radio in a 3 pin device!

Unfortunately, just about every circuit you find uses an inferior setup method for the AGC (Automatic Gain Control) and this gives the chip a reputation of poor selectivity and instability. The circuit used in this kit is little know over here in Europe and was discovered back in the mid 80's by a company called Technicraft from Australia. I can say that this is the best performance circuit I have tried and I was very pleasantly surprised how well such a simple radio can be made to work. The selectivity has been enhanced further by a modification to the coupling between the tuned circuit (the filter) and the radio chip. Let's look at the circuit.

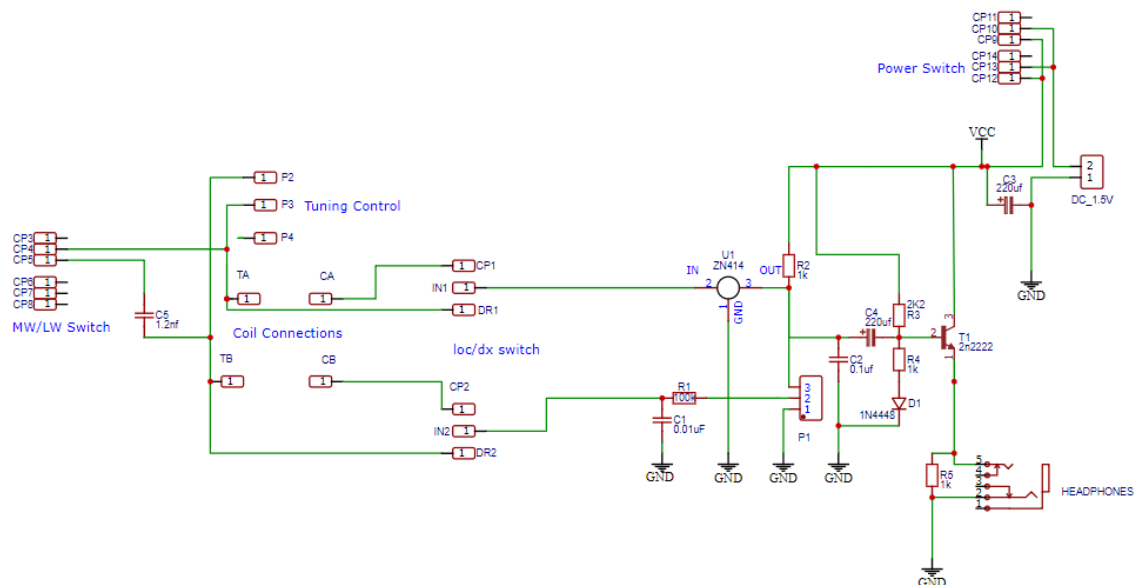



The circuit doesn't show the tuning coil or the coupling coil, these go across points Ta/Tb and Ca/Cb, the tuning capacitor goes between points P2/P3.

The tuned radio signal is passed to the little radio chip from the tuned coil and the coupling coil, the circuit shows a ZN414 but these are no longer available so the modern replacement TA7642 will be supplied.

This chip despite its size contains 10 transistors making a fairly sensitive receiver with about 70db of gain from just this one device. Now this is where most circuits using this chip go wrong. The chip has automatic gain control and can reduce its gain on strong signals BUT the range of this adjustment is limited and it is easy to overload the device, also the supply voltage will cause the gain to change, if the circuit needs around 1.3-1.4 volts to operate correctly but a standard single cell is 1.5v. Often I find a new cell is around 1.6 volts, this means that the chips gain can be even higher and it will oscillate and distort when in use, not nice. The modification to the circuit gives a manual control of the gain and allows it to be reduced if needed to provide good stable operation when faced with a strong signal, without this modification the only way to deal with it was to reduce the gain of the whole radio so it didn't over load, but then on a weak signal sensitivity was low. Our modification allows the gain to be reduced or increased manually so more gain can be used if needed so sensitivity is better.

We do this by changing the feedback voltage start reference point for the AGC circuit via a simple RF Gain control and this allows stable operation even with super strong local signals that would complete knock out the normal ZN414/TA7462 radio circuit.

The next part of the circuit is the single transistor amplifier, the chip itself can only drive high impedance loads such as a crystal earphone so in order to use the normal headphones of today a single transistor amplifier (T1) is used to amplify the signal to a suitable level and to match the low impedance load. (or to be fed to an external amplifier Like the Kanga Bench Amplifier Kit)

These instructions can be viewed in full colour (or printed) from our web site Kanga-products.co.uk, just look on the instructions page for the TRF-1 Radio kit.



Building the Kit

Ok let's check we have all the parts first

Radio PCB

IC1 TA7642

T1 2N2222

Variable Capacitor

Tuning Inductor and rod

C1 0.01uF Ceramic Disk (marked 103)

C2 0.1uF Ceramic Disk (marked 104)

C3, C4 220uF Electrolytic (marked 220uf 25v)

C5 1.2nF Green Capacitor

R1 100K ¼ Watt (See identification chart to help identify resistor values)

R2,R4, & R5 1K ¼ Watt

R3 2K2 ¼ Watt

D1 IN4148

3 x PCB mini switches

RF Gain 10K Standard Potentiometer c/w Knob

3.5mm Stereo PCB Jack socket

PCB AAA Battery Holder

2 x Cable ties

2 x Control knobs

4 x stick on feet

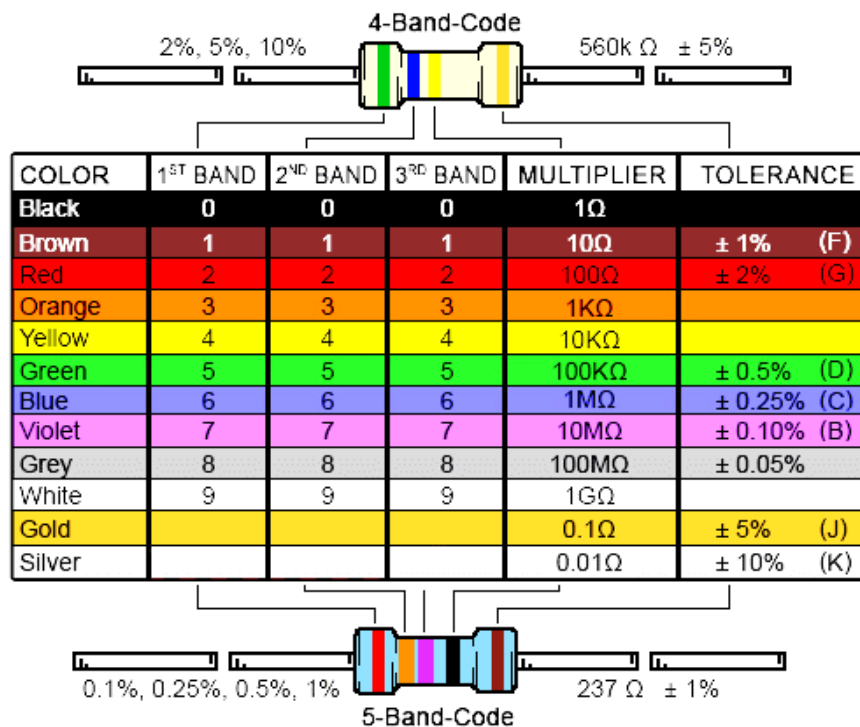

The resistors are identified by different colour bands, the system is complicated further by having 2 main coding systems depending on how many bands are on the resistor. See the chart supplied (Or see this document via the online web site for a colour version of the chart below). I would recommend buying a low-cost test meter if you do not have one. They are very easy to use and can measure the value of the resistors to save you having to work out the value via coloured bands.



Also note that the transistor and the IC look the same, small black blobs of plastic with 3 legs. Take extra care you check the small writing on the flat side of each device.

Let's build our radio

First job is to double check all the parts are in your kit.

Ok let's fit the resistors first, **IT IS IMPORTANT THE RIGHT RESISTOR IS FITTED IN THE RIGHT PLACE!**
The resistors can be fitted either way round.

Start with R1 which is 100K

if 4 bands =Brown/Black/Yellow/Any, if 5 bands =Brown/Black/Black/Orange/Any

Now R2, R4, and R5 which are 1K

if 4 bands =Brown/Black/Red/Any, if 5 bands =Brown/Black/Black/Brown/Any

Now the last resistor R3 which is 2K2

if 4 bands =Red/Red/Red/Any, if 5 bands =Red/Red/Black/Brown/Any

Next let's fit the capacitors

The disk capacitors can be fitted either way but the electrolytic capacitors must be fitted the correct way round.

Start with C1 (marked 103) this is one of the of the two yellow capacitors, make sure you read the value on the side to pick the right one.

Move on and fit C2 (Marked 104), the second of the yellow capacitors.

Now we must fit the larger electrolytic capacitors, these have two leads and one is longer than the other, this is the +V lead, the PCB location shows a small '+' on one of the holes for these leads, the longest lead must go into this hole. The other side of the capacitors body as a '-' sign printed on it to confirm you have it the right way round.

Fit C3 (marked 220uf) and then C4 (marked 220uf) take care they are the right way round as detailed above.

Next fit C5, the green 'Pillow' capacitor which is 1.2nF

Now fit D1, this is a signal diode, it is used to provide temperature compensation as its resistance will change slightly with changes in temperature so ensuring the transistor amplifier is set correctly at all times. It is very important that this is fitted the correct way round, the diode is made from glass so be careful you don't break it. If you look closely at it, you will see one side as a black band. If you look on the PCB you will see one side of the silk screen symbol also as a band shown for D1 make sure that the diode is fitted so the band is on the side that the band is shown on the silk screen printing on the board.



Fit the active devices

A word of warning! The active devices all look the same, black plastic blobs! BUT they are not interchangeable. You must make sure the right one is in the right place and the right way round. Take care and don't rush this.

The first is the TA7642 chip, the heart of the radio, IC1 is shown on the PCB silk screen layout, make sure you fit this as the layout on the PCB shows. Double check that you are fitting the correct part. Look closely at the writing on the flat part of the chip. It should say TA7642.

Now check the transistor, it should have 2N2222 printed on it. Again make sure you fit it as shown on the PCB.

You will find 3 small PCB slide switches, all 3 are the same type, these are for the LOC/DX switch, MW/LW, and Power On/Off . Now these have very close pins so you need to take great care when soldering these in place so you do not form shorts between pins.

We are nearly done now.

Look at the variable capacitor, you will see it as two built in trimmers on the back These should be set to the fully open position, if you get this wrong it's not a show stopper it just changes the tuning a little and for full band coverage it is better to set them this way.

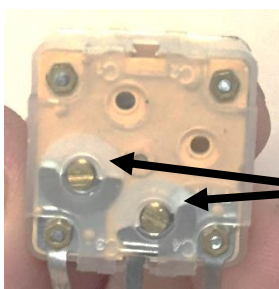

This shows the trimmers closed, not what we want

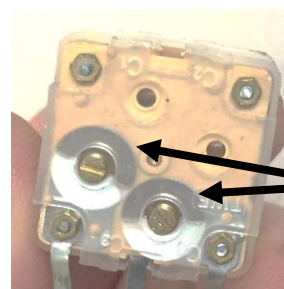

This shows the trimmers open. We want them like this

Now before we fit it to the board I recommend fitting the shaft extender. It is possible to damage the internals of the capacitor by applying to much force to the screw that holds the extender onto the small shaft, look at the shaft and you will see its brass with two small flat sides, I use my cutters to grasp the shaft on these flats and then tighten the screw in the extender, this stops the tightening force from damaging the internals of the capacitor. Once done fit the capacitor to the board.

Now fit the battery holder, the holder as a spring on one side, this is the negative (0V) side. Fit the holder so the spring side is next to the 0V screen printing on the board. The pins on the battery holder are very tough, take care cutting them as the ends will fly off at speed, you really should wear some form of eye protection when doing these jobs so be careful. If your lucky I will have already cut them for you.

The Next two parts to fit are the RF Gain control and the headphone socket, these should be easy to fit parts and can only be fitted one way.



The board when finished will look like this: (but you have not fitted the coil yet so read on.)

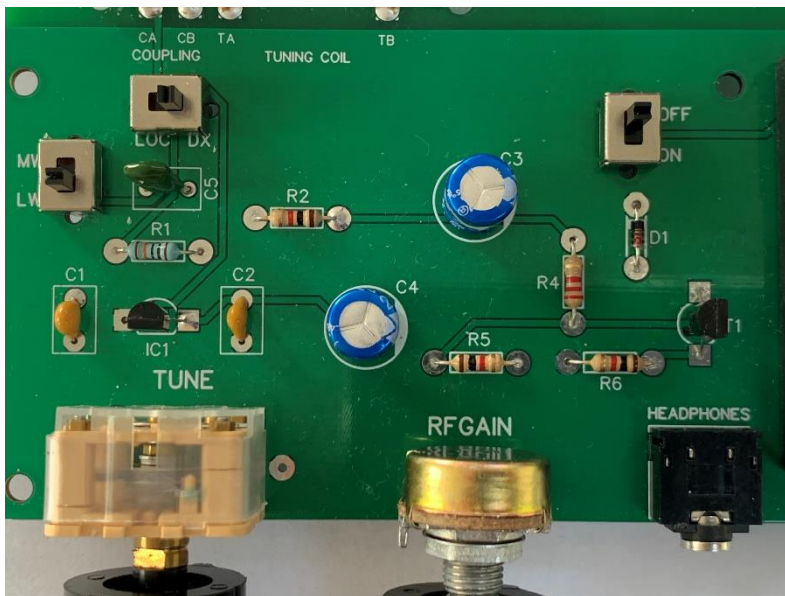

OK now check the solder joints carefully for any dry joints or solder bridges. Are all the parts the right way round? If you're building this as part of a training scheme get your instructor to check out your work.

Completing the build. Fitting the coil.

The last part is the most difficult and will require some care, by now you have gained a little experience in soldering and fitting parts which will help.

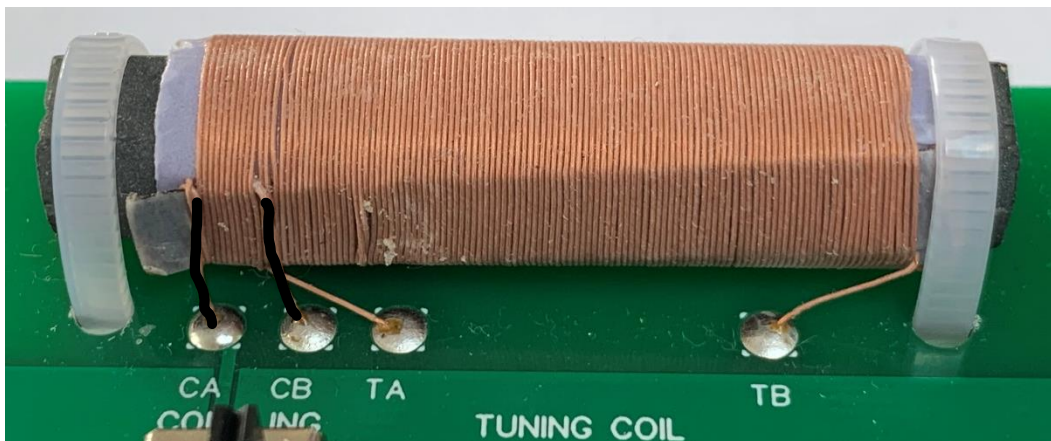

One of the most critical parts of any radio is the input section, this is the coil for the tuned circuit. This little coil will control what frequency the radio will work on and how sensitive and selective the radio will be. I was faced with a decision at design time, I could make it very easy for you and supply a small premade moulded inductor (coil) that would do the job but the sensitive and selectivity would not be too good. The next option was to supply a quantity of wire and a ferrite rod to wind your own coil, in fact a small number of kits were produced for beta testers that way. This option did give somewhat better results but I was still not happy with the receiver's selectivity. Also, I found a wide range of variation in how well the radio worked due to differences in winding the coil. In the end I decided to make the radio with the highest performance I could and so settled on a commercially made higher performance coil, this coil is wound using a specialist wire called Litz wire, it is very thin but gives a much higher performance coil than using one wound from standard enamelled copper wire as I used



in the prototype. The down side of this is that it is a little more difficult to fit but the extra work pays big bonuses as you will find in using the set.

Carefully examine the coil on its 50mm rod, slide it to be in the centre of the rod, just a few mm of rod will be seen on each end. You will see that the coil has 4 wires, look carefully and untangle them, two wires (1 pair) will be coloured black and two uncoloured, DO NOT mix the wires up, this part is very very important, mixing the pairs will mean the radio will not work, position the coil and rod onto the board so the two black wires are on the left hand side of the board, the board has 4 holes for the coil, the first pair are marked CA and CB, the black wires must go into these holes, the holes marked TA and TB must have the un-coloured wires inserted. It doesn't matter which one of the pair of wires is in which hole as long as the two black wires are in CA & CB, the uncoloured wires in TA & TB.

DO NOT cut the wires at this stage or attempt to solder them yet, use the two cable ties provided to secure the coil to the PCB (see picture above).

Once the coil is secure AND you have double checked that the black pair are on the left pull any slack wire through the board to make it a neat job (Don't pull too hard). The wire is covered in a very fine cotton thread and coated in enamel. This would stop any electrical connection to the wire. The wire is too thin to scrape this off but luckily, we don't need to. The coating is designed to be removed by the heat of the soldering iron. Now apply the soldering iron to the bottom of the board at points CA, CB, TA, and TB in turn while applying solder, you will need to keep the soldering iron on each of these pads and wire for much longer than when you soldered any of the other parts. I apply a nice 'blob' of solder and keep the iron on the pad for about 10 secs, often you will see a puff of smoke as the wires insulation melts off. **DO NOT** breathe this in, solder fumes are not good for you! If you have access to a multimeter check for continuity between CA and CB, then between TA and TB.

Testing the radio

If you have not already, fit the knobs to the two controls. Then stick on the four rubber feet.

Fit a AAA battery into the holder and plug in the headphones.

Set the RF gain control about $\frac{3}{4}$ of the way clockwise, flick the power switch to the On position, make sure the MW/LW switch is in the MW position and the LOC/DX switch is set to DX. Adjust the tuning control and you should hear a few stations, you may want to adjust the RF gain control now to bring up the signal of the stations, try tuning in a few different stations, I find about 5 or 6 different stations in my location, you will need to adjust the gain control for best results, stronger signals will need less gain than weak ones but you will soon get the hang of it. Sometimes better results can be had with less gain as a strong signal can cause some distortion or take over the band and drown out the weaker ones, it's a bit of art that you will learn quickly.

The antenna coil and rod are directional, so turn the radio 90 degrees and try again you may find more stations. Do not use the radio next to computer or TV screens as they will cause interference, also fluorescent lights can cause a nasty buzz too.

Now the MW/LW switch, fairly easy one, in the MW position you can receive signals around 500-1600Khz. With the switch in the LW position you will find that you will only receive one station BBC radio 4 (198Khz). It may be possible to change this frequency as it's set by an additional fixed value capacitor that is switched in to the tuned circuit a different value will change the frequency here.



The LOC/DX switch changes how the tuning coil is connected to the radio, in the LOC position we only loosely couple the tuning coil to the receiver, this increases the selectivity a lot but at the cost of sensitivity, hence is only really suitable for local signals or if you live in a strong signal area, in the DX position the tuning coil is directly connected to the receiver and you will hear signals much stronger. You will find that sometime these signals will be too strong for max RF gain and will sound distorted unless you back off the RF gain control. You will find that LW performance will also be better in the DX position too.

There are no hard as fast rules for which position will give you better result just try both and have a play.

Trouble Shooting:-

Most of the problems are due to the coil not being soldered correctly, double check that the black coloured wires are in the correct holes CA and CB (See photo in that section of the instructions) the wires from the coil are insulated with a solder meltable coating, this coating needs a lot of heat to melt so re-apply the soldering iron and a little more solder to each point of the 4 wires from the coil, keep the heat applied for about 10 seconds at each point.

Any problems drop me an email

Paul@kanga-products.co.uk