

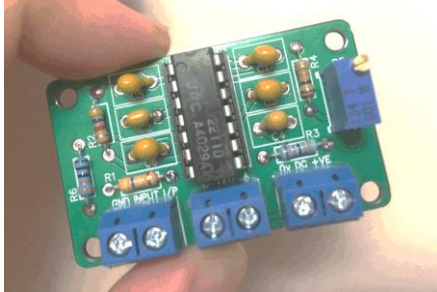

The Magic Eye CW Tuning Indicator (Module Version)



The Magic eye allows you to easily net onto a CW signal reliably and quickly time after time.

With today's radios fitted with razor sharp CW Filters it's important to be bang on your QSO partner's frequency. The magic eye will ensure that you're tuned within a few Hz of the correct netting frequency.

In days gone by a small illuminated green valve was often used to indicate accurate tuning. The Magic Eye pays homage to these devices by providing a modern Green LED that only illuminates when you are tuned correctly.

The circuit uses a tone decoder type circuit that allows the user to adjust the desired frequency of operation to their preferred side tone pitch.

The module will work with a very wide range of input signals, from a few mV from a connection to a Data out socket of a HF radio to an input of a few volts from a connection across an external loudspeaker.

Let's see the circuit for this module.

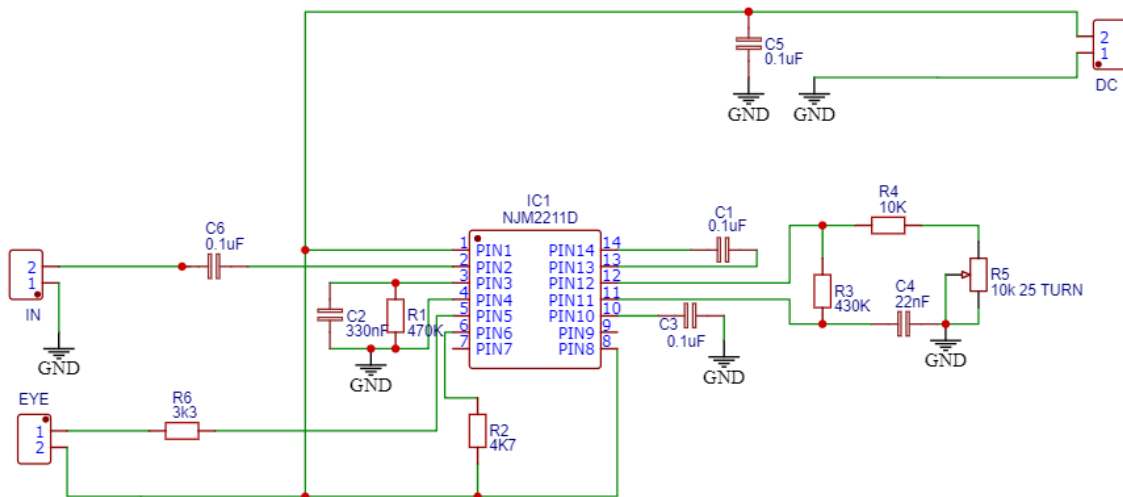

Please refer to the parts list for values, some have changed since the circuit was drawn.



KANGA PRODUCTS

Electronic Kits For The Radio Amateur

First stage let's see the parts list and check we have all the parts

- 1 x Magic Eye PCB
- 1 x 14 Pin Socket
- 1 x NJM2211D Decoder Chip
- 3 x 2 Pin Terminal Blocks
- 1 x Green 5mm LED
- 4 x C1,C3,C5, & C6 0.1uF disk Capacitor
- 1 x R4 :- 12K Resistor
- 1 x R3 :- 430K Resistor
- 1 x R1 :- 470K Resistor
- 1 x R6 :- 3K9 Resistor
- 1 x R2 :- 4K7 Resistor
- 1 x R5 :- 10K Trim Pot
- 1 x C2 :- 330nF Capacitor (marked 334)
- 1 x C4 :- 22nF Capacitor (marked 223)

Building the Magic Eye

First stage is to fit the 14 pin IC socket, look at the PCB and you will see the silk screen layout for the socket, it shows that the notch on the socket should be towards the top of the board. Install this part that way round, make sure its flush to the board and solder all 14 pins. Check you have no shorts between pins. This is the most commons source of problems.

Next fit the resistors

R1 470K resistor, this like all resistor can be fitted either way round. I recommend using a meter to check each resistors value before fitting.

Next fit R2, R3, R4, R5 (That's the 10k Trimmer), and R6.

Now fit the capacitors

First fit the 4 ceramic disk capacitors C1, C3, C5, and C6

Now fit C2 which is one of the two yellow capacitors value 330nF (marked 334)

Now fit the last capacitor C4 the last yellow capacitor value 22nF (marked 223)

Nearly done, let's stop a second and double check our work, look for any shorts between pads or and badly soldered pins. Make sure all leads are trimmed.

Finial a decision for you, you can if you wish hardwire the power, input and LED to the module direct or fit the supplied 2 pin terminal blocks and make connections to them, the choice is yours and depends how and where your using the module.



KANGA PRODUCTS

Electronic Kits For The Radio Amateur

When connecting the power make sure you are careful with the polarity, also when connecting the input note that one side is grounded. This is common with the 0v path so make sure you connect the audio the correct way.

The LED you will note as two leads of different lengths

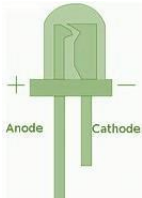

The long leg is the **Anode (+ve)** leg Marked A on the PCB

That's means the short leg is the **Cathode (-Ve)** leg
Marked C on the PCB

Wire the LED to the board or fit it to a panel, again your choice.

How to setup the Magic Eye.

First you need to find a nice steady CW signal. Take time and tune it in, once you're happy with the tuning we can set the Eye to activate on this tone by SLOWLY adjusting the trim pot. The bandwidth on the active region is designed to be about 25Hz but in practice due to component tolerances the real life bandwidth will likely be a little higher. As you turn the trim pot you will see the LED come on, make a mental note of the position of the pot at the LED on point, carry on adjusting the pot till the LED goes out, the on and off points are the bandwidth of the PLL. Adjust the trim pot to half way between these two points and check the tuning, it should be set now and in future you can just adjust the radio tuning till the LED illuminates in sympathy with the incoming Morse.

Another option is to use the rig's own side tone when you key the radio and adjust the modules tune to light on this tone. Of course if you have a calibrated signal generator you can always feed the magic eye with a signal at the frequency you have set for your rigs side tone.

That's it, job done. Module ready to be mounted. Let me know what you think.

73 Paul M0BMN sales@kanga-products.co.uk



KANGA PRODUCTS

Electronic Kits For The Radio Amateur

Typical installation options

Option 1 :-With external loudspeaker

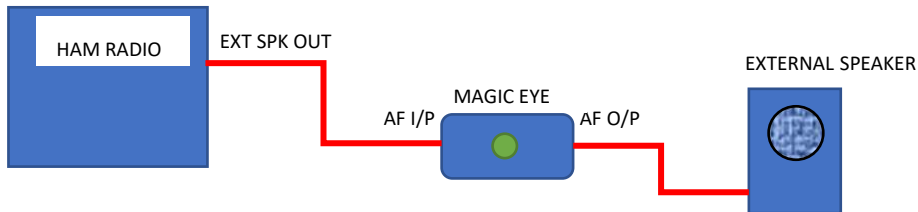

Option 2: Low level AF source

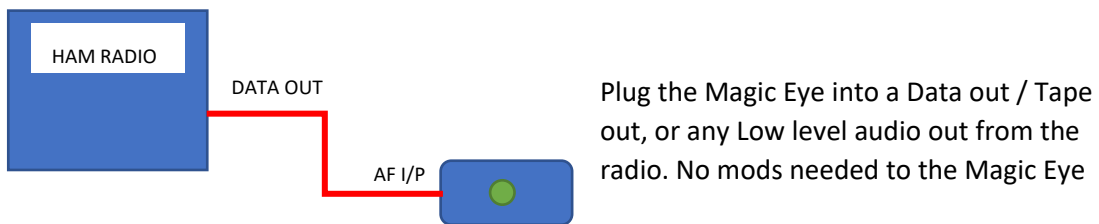

Wiring up the Module

