



**KANGA
PRODUCTS**

'RockRose' CW Transceiver

40m Kit Manual and User Guide

Rev 2 01/04/2025



Intermediate Build Crystal controlled Transceiver.
2 frequency operation from one crystal
Built in Iambic Keyer (Mode B). One touch auto CQ Calling
Bug emulation mode and Straight key over ride
Direct Conversion Design
Part SMD design (Pre-installed)
approx 30 parts to fit. Just two simple toroidal coils to wind
Front Panel Channel switch
approx. 3 Watts (Adjustable) on 40m
Active Audio Filter
Sinewave CW Sidetone
Visual RX/TX indicator
9-14v DC Operation Total built weight approx. 165g



Introduction

Welcome to the RockRose CW transceiver. About two years ago I started looking for a simple Transceiver kit that would replace the FOXX3 and if possible, the Rockmite kit that Kanga offered too in the past.

After some hunting I came across a kit that was produced over a decade ago by CRK (Chinese's Radio Kits), the kit was no longer offered but following some discussion with Adam Rong (the owner of CRK) we bought all the old stock of PCB and parts with a view of offering the CRK10 kit again. A few kits were built up but it was clear that here in the UK the kit suffered from strong AM breakthrough and so the original kits and boards never got used.

The CRK10 kit was inspired itself by the Small wonder Labs Rockmite and a few other similar kits already being sold in China at that time. The Kit was never offered in the UK or Europe for that matter but was a popular kit in Aisa and the USA. Over the last two years this has been an ongoing project for me, a divergence from which evolved into the Rooster kit we offer. Time as moved on and so has the design, I am glad to say we are now in a position to offer the The 'RockRose', why is it called the RockRose? Rock as its crystal controlled after all and Rose, well at the time of re-designing the original kit to make it more useable in the UK/EU my mother past away and her name was Rose, so I called it after her hence the RockRose. This new transceiver builds on the good points of the original CRK design but adds TX/RX indication LED's, better front-end filtering, adjustable power, switchable offset which gives two operating frequencies from just the one crystal and the low pass filter has changed to give much better harmonic suppression too. The original design used a high-quality case that is still available today so we stuck to that despite its relatively high cost.

The RockRose can give two operating frequencies from the one crystal. We are using a direct conversion receiver in the RockRose, these type of receivers do have disadvantages but in this kit we are turning a disadvantage to our advantage. DC receivers receive on both sides of the carrier frequency so by switching around the transceivers offset from RX to Transmit we get two usable frequencies approx. 700Hz-800Hz apart. Now we have the ability to QSY from the calling frequency (unlike the Rooster). There is a price to pay for this, we no longer have an external adjustable RIT control (it's now a set once control during alignment on the PCB). If you simply MUST have RIT then the single frequency Rooster may be the better choice for you. Many other radio like the well know Rockmite have excluded any RIT control from their designs too.

The RockRose also has had an efficiency boost compared to the Rooster by using toroidal cores and a few other tweaks in the LPF, this has resulted in a considerable power increase too (approx. 50% more power than the Rooster) for about the same current consumption (if not less)



The RockRose is designed to be a single evening or weekend project that will be fun to build and even more fun to use but with more parts and a more complicated alignment procedure we feel the RockRose is more suited for intermediate level builders. If you're not experienced with building kits the Rooster is still a better starting point and we will continue to offer that too. The RockRose kit uses a mix of SMD and through hole parts, ALL the SMD parts are pre-installed but still leaving about 30 plus parts to fit to complete the transceiver. The kit can be completed in a comfortable 2-3 hours by an experienced builder but a less experienced builder may want to take more time and this would be a good choice for an intermediate level build-a-thon or club build with more experience helpers and more time if needed.

The RockRose has a built in Iambic keyer (Mode B) that allows adjustment of the keying speed, it also has a built in Auto CQ call feature too. Another feature allows selection of Iambic/BUG/ or straight key modes (see instructions section later in this manual for more details)

The RockRose will require a suitable antenna with a low SWR, headphones, power source, and of course a Morse Key!

Disclaimer

The kit is designed to be built by Ham radio enthusiasts and in order to use the finished product you need to hold a valid ham Radio licence that permits operation on the RockRose frequency in your locality.

We offer the kit as is, and do not guarantee the kit assembled by yourself can meet your local regulatory requirements, including spurious, environmental or other requirements.

Product safety Notice. User agreement of responsibility

The RockRose is supplied as a self-build project for educational use by licenced and qualified amateur radio operators. Part of the standard training for the Radio amateurs licence covers the use of basic hand tools and how to use them safely. The builder takes responsibility for ensuring that they work in a safe and responsible manner, we recommend that PPE equipment is used during the build of this project including eye protection and fume extract when soldering. Kanga accept no responsibility for any issues arising from the construction of this kit. If you have any issues with accepting these terms please return the kit unbuilt for a full refund.

First Job Read the instructions! Then come back to this page

Parts Inventory

The main parts are presented in a strip of clear tubing, separated in sections. Each section covers a small number of stages in the instructions, only open the section you are working on at that time so you don't lose any parts. Start at the end with the DC connectors and 3.5mm PCB sockets.

Item	Qty	Value	Comment
Enclosure	1	RockRose Aluminium Case	CASE
PCB	1	RockRose PCB	SMD Parts Pre-fitted
Parts Pack Section 1			
DC PWR SKT	1	2.1mm DC Power Socket	PWR
3.5mm Jack	2	3.5 mm Stereo Type	PHONES/KEY
Capacitor	1	10nF MLCC Cap 2.5mm	C39 Marked 103
Capacitor	2	10nf Green 5mm	C29, C30 Marked 103J
Slide Switch	1	SPDT Mini switch	SWT
Push Switch	1	Command Switch	PUSH
Parts Pack Section 3			
NE602	1	Mixer IC on adapter board	IC1
Keyer MCU	1	MCU 12F629 Keyer	IC3
IC Socket	1	8 way IC Socket Turned Pin	IC1 Socket
IC Socket	1	8 way Standard DIP socket	IC3 Socket
Parts Pack Section 4			
Transistor	2	2N3904	Q1, Q2
Transistor	1	2N3906	Q4
Transistor	1	2N4401	Q5
PA	1	2SC1162	Q6
PAD	1	Thermal Pad	PAD
BNC	1	BNC Panel Socket	ANT
LED	1	Dual Colour LED	LED
Zener	1	33v Zener Diode	D3
Feet	4	Rubber Feet	Feet
Parts Pack Section 5			
RockRose Front	1	Front Panel	Punched and printed
RockRose Rear	1	Rear Panel	Aluminium Rear Panel
Parts Pack Section 6			
M3 Nut	1	M3 Nut	PA transistor Mounting Nut
M3 Screw	1	M3 Black Screw	Screw (for PA)
M2.5 Screw	8	M2.5 Screw for Panels	Fixing Screws

Band Section 40m Pack

Parts Pack Section 4			
L1	1	10uH Radial Inductor	See Instructions for details
L4	1	3.3uH	See Instructions for colours
Winding Wire	1	1m enamelled Copper wire	LPF Wire
T37-2	2	LPF Toroidal cores (Red)	LPF Cores T37-2 L2 & L3
C6, C10	2	470pf	C6, C10 Marked 471
C7, C11	2	33pf	C7, C11 Marked 330
C8	1	1000pf	C8 Marked 102
C9	1	130pf	C9 Marked 131
C15, C16	2	100pf	C15, C16 Marked 101
C35	1	150pf	C35 Marked 150P
C35A	1	Not used for 40m	C35A
C40	1	56pf	C40 Marked 560
XTAL	3	40m Crystal 7.030MHz	X1, X2, X3
Trimmer (Yellow)	1	Trimmer Capacitor 60pf	C23
Trimmer (White)	1	Trimmer Capacitor 10pf	C24
Trim Resistor	1	500 ohm Trimmer (Blue)	PWR Set

Important

The RockRose is a relatively easy to build transceiver BUT you need to carefully follow the instructions, do not move on a stage until you are sure that you have completed the previous stage correctly and fully. All parts must be fitted neatly and their leads trimmed flush. **I cannot stress strongly enough that unless you follow the instructions and make sure that each part is fitted correctly you will not successfully complete the kit.**



Lets make a start with the kit

Get familiar with the main PCB.

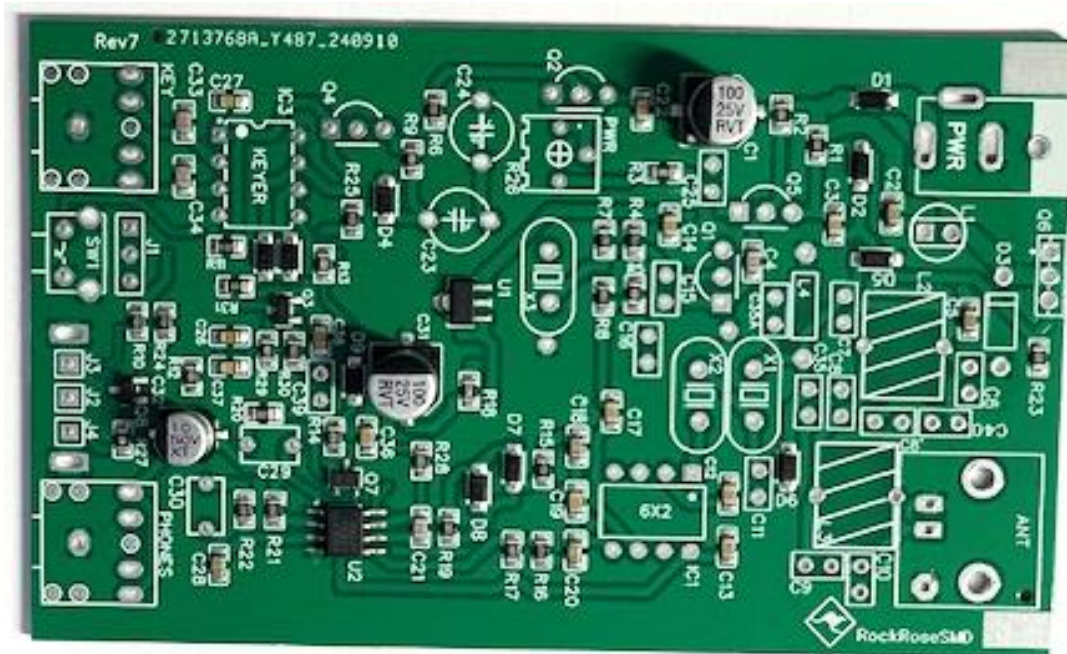

You can see many parts are pre-fitted for you, there are just under 40 parts left for you to fit. Some of the parts are close together so you will need to take extra care when soldering. Make sure all the parts are fitted flush to the board if the instructions call for it, and trim the leads as flush to the board as you can. There is not a lot of room under the board when fitted in the case.

The parts for the kit are in a number of sections, start with section 1. That is the end with the DC and 3.5mm sockets, this will cover the first few stages of the build.

You will also have a band specific bag of parts too, that will depend on which band you are building for.



Stage 1 :- The DC input socket

The first part of the build is to **fit the DC socket**.

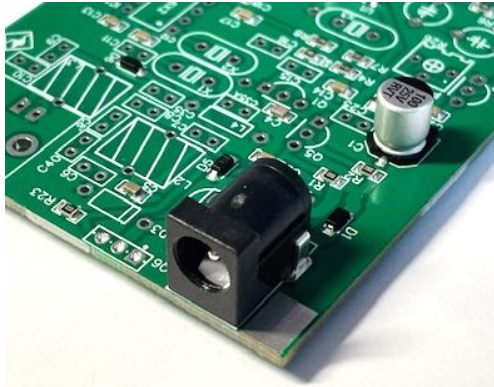

The socket must be fitted so that it's flush to the board and level with the edge of the PCB. The position for this is labelled PWR. It must be square to the edge of the board as shown here. The silk screen printed layout can be used to make sure it is positioned and aligned correctly.

Solder one pin first and check the part is correctly fitted. Once you're happy that it is right, solder the remaining two other pins.

You need to make sure all parts are fitted correctly, I have seen builders rush to fit parts and then try and correct their mistakes later. It doesn't end well. Do it once and do it right to start with, we have an old saying here in the UK that fits 'measure twice, cut once'



Now trim the three legs so they will not short out on the case when fitted.

Do not move on a stage until the current stage you are working on has been completed correctly and double checked. The biggest problem identified with the beta testers was poor soldering and rushing to get the kit built. Do not take short cuts. Each part is as important as the next. Save yourself problems later by taking care at each stage.

Testing your work

Ok we have only fitted one part but that will allow us to do some basic testing on the board.

We can test the voltage regulator.

I suggest using a current limited supply if you have one and monitor the current the board draws.

VERY IMPORTANT WARNING !

I have had a couple of people that have damaged their beta kits at this early stage. It is vital that you make 100% sure that your meter used for testing is set to **VOLTS** not CURRENT, if set to current you will be shorting out the voltage regulator on one test and be shorting one SMD transistors right across the supply lines with a resulting 'puff' of smoke as the SMD transistor boils! don't do it! Check that meter is set correctly. This is why a current limited supply set to say 10mA is great for this test.

For all the following tests I have used a 12v DC supply.

Apply 12v to the board via a suitable power lead (Centre pin positive) to the DC input socket of the board (2.1mm plug needed)

The current consumption should be just a few milliamps, the overall finished receiver will be around 20-25mA when complete.

Important:- Make sure you select DC Volts on your test meter NOT current. Trying to measure voltage when the meter is set to current may damage the meter and will damage the kit!

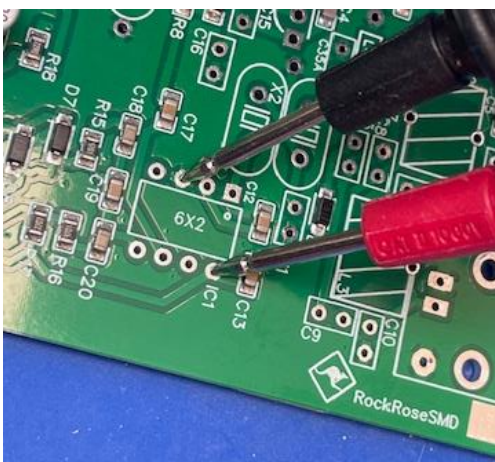

On the board you will see the position for IC1 (also marked 6X2). Use a **DC Volt meter** to measure the voltage across the pads as shown here in this photo (Pin 3 =0V , Pin 8 = 5v) You will see about 5 volts +/- 0.1v.

That completes the first stage and the first tests.

Important

Now turn off the power and unplug all the leads before you move on to the next stage. After each stage of testing remember to unplug all leads from the RockRose!

Take the same care with each of the following stages.

Stage 2 :- Phones and Key sockets

Read ALL this section BEFORE soldering anything!

You must do the checks I tell you in this stage or it will most likely not fit in the case!

The two jack sockets are used for the key and the headphones. They fit right on the front edge of the PCB. Both sockets are the same type. Make sure you **fit these on the TOP of the board** as shown here.

Make sure that all the pins pass through the board and none are folded over when you fit them. The sockets will **NOT** be flush with the board when fitted. They sit on small little plastic feet. Make sure that they are sat correctly and nice and flat as shown in the picture below.



Now the RockRose lives in a nice aluminium case. These sockets need to be correctly positioned if the board will go into its case. So, find the case and the front panel out now and fit the panel to the case, no need to tighten the front panel right down it helps if we can jiggle the front plate a little for now.

I solder **one pin** of the two sockets first and then slide the PCB into the case. Make sure that the sockets can pass through the two holes for them in the front panel. You may have to jiggle the front a little for them to sit correctly or even re-check the sockets position on the PCB, if all ok then remove the PCB from the case and solder the remaining pins (then recheck the fit, I recheck after each pin I solder!)

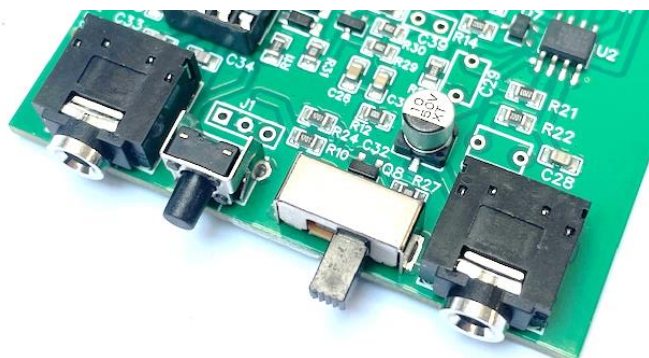

Don't rush this job. We need to be sure this will fit the case later.

Next we can fit the other front panel controls, we have a **two way switch** (Frequency Selection) and a **small push button** that controls the keyer.



Makes sure these sit right down on the PCB, I tend to solder just one pin on each and check they are correctly aligned by sliding the board back into the case.



Now if you have followed the instructions and just read this first you can go back and complete this stage.

Stage 3: The Keyer

Now we can build and test the keyer circuit.

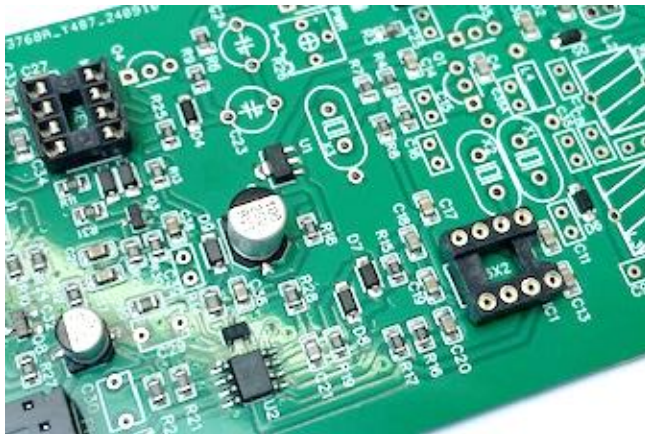

First let's **fit the two IC sockets**. You will see you have two different types. One is a standard DIP type socket type and one a turned pin type socket. The standard 8-way DIP socket is to be fitted near to the Key socket for the Keyer chip (IC3) you will notice the socket has a notch in one end, the PCB layout also shows a notch too, make sure you fit the socket to match the outline on the board, the same note applies to the turned pin

socket that should now be fitted in position IC1.

Now we have a few capacitors to fit. Two are larger green capacitors and these are what we will **fit next, C29 and C30**, both are the same value 10nf. They will be marked 103J. These can be fitted either way round.

Next **fit capacitor C39**, this is a smaller yellow capacitor and will be marked 103.

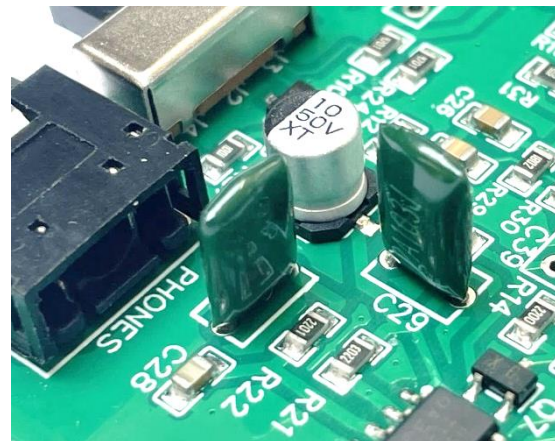

Again this can be fitted either way round.

Now CAREFULLY **fit the keyer control chip**. Currently we are using the original CRK10 control chip code but that may change as we move forward. The chip MUST be fitted the right way round, on the chip there is a small dot near one of the pins, this is pin 1. This should be nearest to C27 on the PCB.



Now we can do another more meaningful test.

Plug in headphones, a paddle key if you have one, a straight key if you don't. Now while wearing the headphones plug in the power lead and power up the RockRose. If all is well you will be greeted with the letter 'A' (if you have a paddle key connected) or the letter 'M' if you have manual (Straight) key connected. while we are at this point let me just point out how the keyer senses the key type. On power up the keyer looks at the key socket, if it sees a Stereo plug then it sets itself up as an Iambic keyer, if it sees a Mono plug it sets itself up in straight key mode. The keyer can also emulate a Bug key but more on that later in the user guide section. It is important that you use a mono plug with a straight key **not** a stereo type.

Now you can try the key, the right paddle produces Dahs and the left Dit's, that's the normal right handed setup. If you are a lefty then I am sorry to say you will need to wire the plug of the key the other way round if you want the Dits and Dahs reversed.

IF using a straight key you should just get sidetone when you hold the key down.

The Iambic mode will be around 12 WPM but we can change the speed later (again see user guide)

If you press the small button the keyer will send a CQ call, the callsign will be missing (you need to enter your call sign later, details in the user guide!) to cancel a CQ call you need to press and hold the button a couple of seconds.

Well done you have checked the keyer and most of the audio chain too.

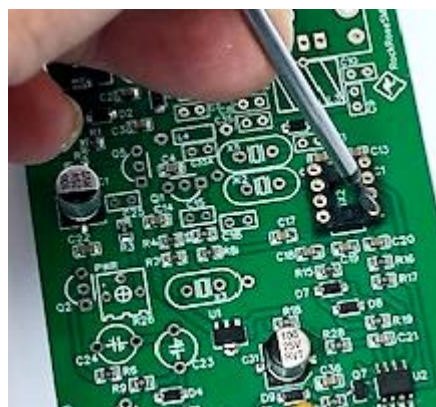
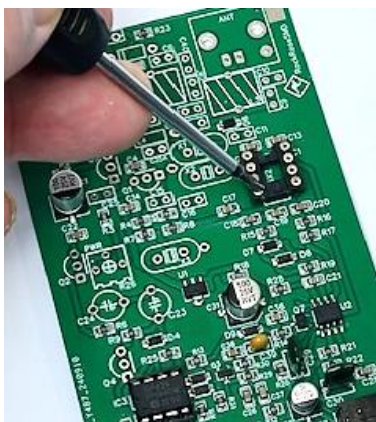

We can do another test now the **Buzz test**.

The audio from the mixer chip is presented on pins 4 and 5 of IC1. Touch these points with a screw drive we should hear a buzz in the headphones.

Stage 4 The Transistors

Most of the transistor are pre-fitted as they are SMD parts. But not all of them. We have used traditional though hole transistors for key areas so that you could replace them at a later date if you damage them though mis-use or problems.

We have **4 transistors to fit** just now, you need to be VERY CAREFUL

All the 4 parts we are fitting look the same but you must be sure to fit the correct one in the correct place. The other transistors are pre-mounted SMD types

Q1 & Q2 are 2N3904 transistors

Q4 is 2N3906 Transistor

Q5 is 2N4401 Transistor

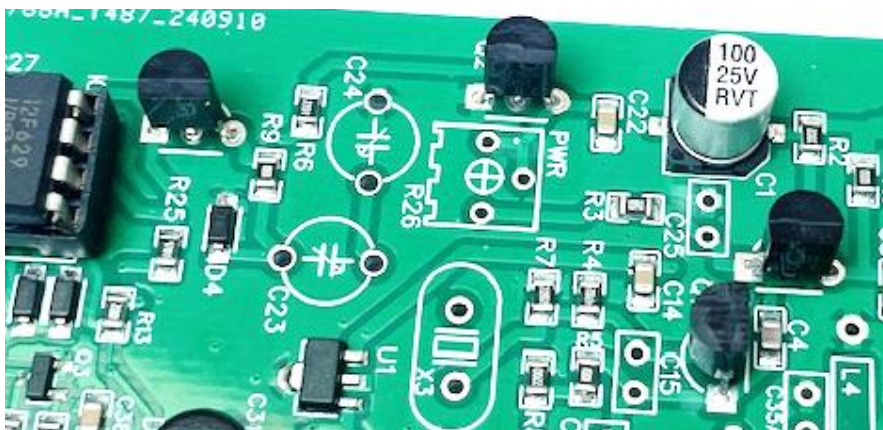

These can **NOT** be swapped around and must be fitted the correct way round too. The PCB layout shows which way round to fit them.

The transistor type is printed on the flat edge of each transistor, the writing is very small so be careful that you choose the right ones. Use a magnifying glass (you should find one with the PCB) if you can to be sure you have the right one. Do not try and push these right down flush to the PCB they will sit about 3-5mm above the top of the board.

Stage 5 Trimmers and Oscillator

First a Note about capacitors.

The kit uses a number of different value capacitor. It is vital that the right ones are used in the right places. They look the same but they are not, look carefully, on one side of the body the value will be marked. The markings can be very small so you may need to use a magnifier to read them if your eyes aren't the sharpest. I use my mobile phone in camera mode to zoom into the writing on the body of the capacitors if I can't read them. This method can be used on any parts you are not sure about and even to check the board for solder bridges too! Identifying the capacitors correctly maybe the stage many people struggle with, take your time and be sure that the right ones go in the right place. It is possible that the kit will work if one or two capacitors are fitted in the wrong place but the performance/power levels could be adversely affected.

We are now moving onto the RF side of the transceiver. You will have 3 trimmers with the kit. These control the power level, RX and TX frequency.

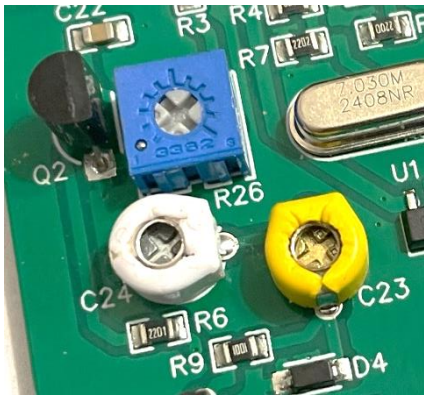

Fit R26 (PWR Control), then fit the two trimmer capacitors, C24 (White) and C23 (Yellow) note which way round they are fitted here in the photo, the flat edge needs to be as shown, fit yours the same.

**** IMPORTANT ****

With the board in the position of the photo here turn the Blue trimmer fully anticlockwise. That is Min-power and saves problems while we align things later.

A few more parts to fit before we can test the oscillator, two capacitors need to be fitted now (C15 and C16) both of these are small yellow ones (marked 101) and then the three crystals. First **fit C15 and C16** as below.

Now find and **fit the three crystals**, they are all the same type so you can use any in any



place. The crystals need to be fitted flush to the board, solder just one pin of each first and check that they are nice and squarely in line with the screen printing on the board. Once happy solder the other pins.

Now testing the Oscillator.

For this test you need to plug in the mixer chip, it's on a little SMD adapter board. The board has the pins 1 and 8 marked, plug the chip in so that pin 1 is nearest to the two bandpass crystals.

You may have received a DIP chip version of the NE612 instead of the SMD version, if so use that.

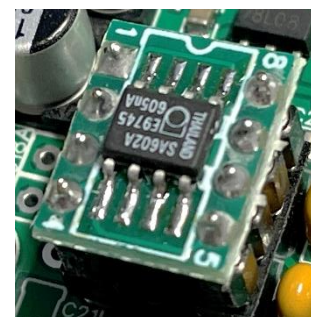

To perform this test you will need the help of a 40m receiver/transceiver.

Set the main station receiver to 7.030MHz.

Turn on the RockRose. Set the front switch to the left hand side position. You may need a wire from the antenna socket of the main receiver to be put near to the RockRose to hear its local oscillator signal but it shouldn't be too hard to find it around 7.030MHz when you have found the signal press the little button on the RockRose or press the key. The tone you are hearing on the main receiver will change, it may disappear and reappear but it should change. Don't worry about the frequency being off at the moment, we will sort that soon.

If you can check the current with the key up it should be 10-20mA, key down should be more, around 50-70mA. Now disconnect any leads and power from the Kit. It may be a good idea to unplug and put the mixer chip safe for now.

Stage 6 Front End Filter

We are really moving along with the build now.

First we can **fit the capacitors**.

C7	33pf (Marked 330)
C11	33pf (Marked 330)
C35	150pf (Marked 150P)

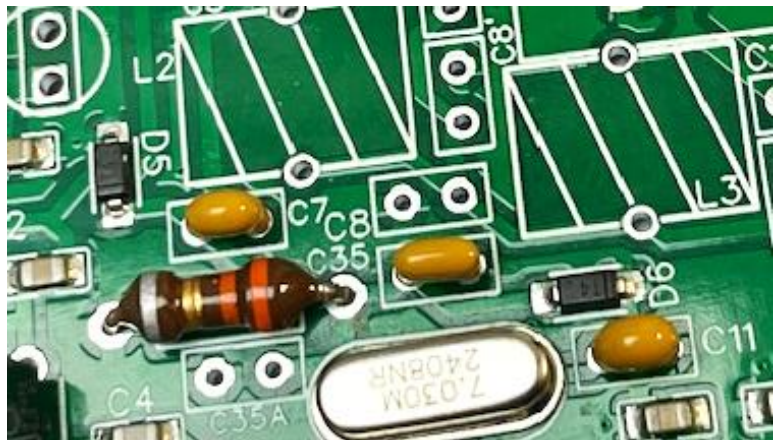

Now we can **fit the front-end filters inductor**.

This is L4 and is a 3.3uH Inductor with bands of Orange, Orange, Gold, Silver.

Many simple radios like this just use one crystal as the bandpass filter (like the original Rockmite) , in areas with little commercial AM broadcast stations that works well enough but here in the UK and Europe where we are blasted with KW power houses of AM stations a single crystal front end just will not cope, in fact twin crystal front ends are still likely to suffer, in this design we have used the twin crystal design and also a more traditional LC filter too. All these together give good AM broadcast rejection.

We are using a small high Q molded inductor for this filter section. We need to shape the legs to fit the board. To do this bend the legs 90 degrees to the body of the inductor right where the wire leaves its body.

The value of the inductor will depend on what band the RockRose is on, for 40m it will be a 3.3uH (Coloured Orange, Orange, Gold, Silver bands)



The values for this filter are calculated from the following formula.

$$f = 1 / (2\pi \sqrt{L C})$$

So with a 3.3uh inductor and a 150pf capacitor (C35) we have a centre frequency of 7.154MHz which is bang in the middle of the 40m band.

Stage 7 PA Protection diode

Now to give some protection to the PA transistor we will use a Zener diode across the PA output. This a commonly used trick. Transistors have a breakdown voltage and exceeding that can cause the transistor to fail, depending on the SWR presented to such a simple PA as the RockRose's the output voltage can rise to dangerous levels (for the transistor that is!) with high SWR's. The Zener diode limits this voltage and clamps down if the preset level is exceeded. We have been conservative with the value of the diode and it will kick in well below the threshold that the transistor can work with. Don't think that this makes the PA immune to problems it doesn't! excess heat and high currents will still cause it to fail if it's treated with no respect so be warned. That said for the cost of a diode it's well worth fitting one.



The diode needs to be bent to fit and then **fitted such that the black band is nearest to the D3** marking as shown here.



Stage 8 The Low Pass Filter Capacitors

The output from the PA is rich with harmonics, the level of which would cause problems on higher bands so we have included a suitable low pass filter for the RockRose.

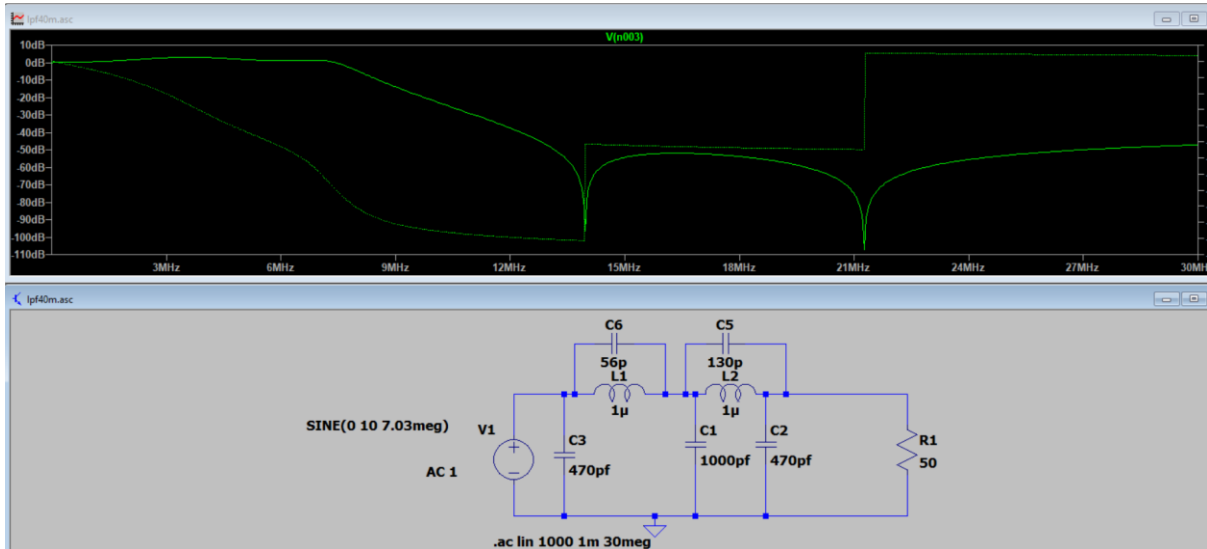

With the values we have used we should exceed FCC harmonic reduction requirements.

So lets **fit the LPF capacitors**, it is important to only use COG/NPO type capacitors in these stages as otherwise the values will change as they warm up in use.

The main capacitors are

- C6 :- 470pf (Yellow marked 471)
- C10 :- 470pf (Yellow marked 471)
- C8 :- 1000pf (Yellow marked 102) Note **NOT** C8'
- C9 :- 130pf (Yellow marked 131)
- C40 :- 56pf (yellow marked 560)

Be sure to fit the right value for each capacitor, use a magnifying glass if needed to read the value of the capacitor, you could use the photo app on your phone and zoom into each part to read the value printed on them.

Check and double check that you have the right part before you solder them in place. It will be much harder to remove and refit them later!

Fit these and trim the leads.

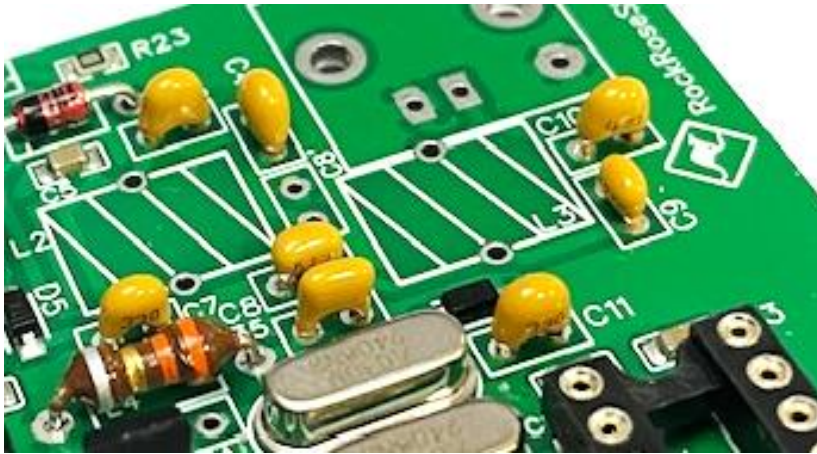

NOTE!
On the 40m version there are no capacitors to be fitted in C8', C35A, or C25

Stage 9 Inductors

We now need to **fit 3 inductors**, the first is very easy L1, this is a radial lead vertical inductor of 10uH .

L1 is to be fitted just to the side of the DC power socket.



The other two inductors are not so easy.

Now we need to make these two LPF toroidal inductors ourselves.

We are aiming to make these 1uH at this stage in theory to match the LPF design.

More maths and additional information! (Skip if you wish)

We need these inductors to be physical small to fit into our tiny case so we are limited to which cores we can use, I normally use T50-2 cores in most of my homebrew circuits but they are a little large for the RockRose. The next size down is T37-2 cores. T37 cores are good for up to 10 watts so our 3 watts is not going to be a problem at all.

The Cores number is made up by two parts; T37 and then 2, both mean something different

The first reference is T37, that is related to the size of the core in 100^{ths} of an inch (so 37th of an inch is just under 10mm)

The second number is related to the mix of materials that the core is made from, this mix will give a different inductance per turn of wire, each 'mix' has a different magnetic permeability rating. In addition to the difference in permeability different mixes have different efficiencies at different frequencies. The type 2 we are using offer good efficiency

up to 10MHz , these are fine for 40m, if we looked at 30m or higher we would use a different mix (type 6) to keep the efficiency high. Type 2 cores are colour Red, type 6 is Yellow.

A little word to the wise now, If you build your own filters using such cores be careful to buy them from a reliable source. Some sellers offer unrated cores just painted red or yellow, the performance of these 'fake' cores is very poor and the value of inductance could be anything. Remember you get what you pay for!

With good cores we can calculate the number of turns needed to give a certain inductance. The core type we are using, type 2 has an AL (permeability rating) of 4

$$A_L=4 \pm 5\% \quad uH=(A_L * Turns^2)/1000$$

Feeding in the requirement for an inductor of 1uH gives us 15.8 turns. So the nearest is 16 turns. It has been found in practice that the calculated value is with the coil well spread out over the core. The way we are mounting the core on our PCB tends to bunch up the wire a little, this as the effect of raising the inductance from the calculated value. Therefore, we have found that reducing the turns to 15 restores the correct inductance. The photos here are of our prototype and that had 16 turns. The power output was reduced a little with the 16 turn inductors, later we fitted 15 turn cores and the power level was corrected. So we will use 15 turns on the RockRose.

End of lesson.

Right so let's get on with making these inductors.



The band pack as two cores and a length of wire .

The wire is about 1m long, straighten this out and then cut it into two equal lengths.

Winding inductors is easy if you take care with the counting, one turn off can change the results. Each time the wire passes through the core it counts as one turn. The picture here has two turns **note the direction** of the windings, pass the wire through the core from the bottom and wind in an anti-clockwise direction until you have a total of 15 turns on the core.

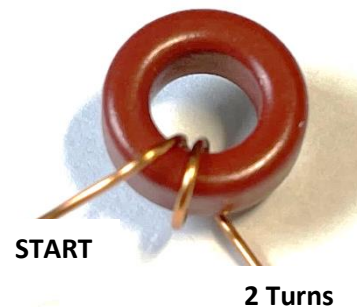

When you have completed the first core do just the same for the second.



TOP TIP To be sure you have counted the turns correctly use your phone's digital camera and take a picture of the core, you can now increase the size so it's easier to count the turns. Remember that we are using 15 turns NOT 16 as this photo shows.



Start with L2, first job is to cut the leads to about 25mm in length from the core's body and scrape the varnish off the two leads. The wire we are using has a solderable enamel but it still is much better to clean off this enamel before trying to solder the leads.

TOP TIP, you have some wire left over after winding these cores, use that first to practice cleaning the enamel from, it's easy to apply too much pressure and cut the leads from your cores, so get a feel for the job using the offcuts first.



Pass the inductor's leads into the PCB as shown here. There are two holes for each inductor.

Pull each lead a little at a time until the core is set on the PCB. Once down, bend the leads under the board a little to hold it in place, now to solder the two leads, the leads may still have some varnish on them, apply the soldering iron to the joint and give it a couple of seconds to warm the wire and pad, then add a little solder to the joint. Keep the soldering iron in contact with the joint for at least another 5 seconds so that any excess varnish gets burned off, you may need to apply a little more solder.

The joint should be made and often you will get a puff of smoke from the joint as any remaining enamel burns off. Try not to breathe this in! Inspect your work and then when happy trim the wires. This can be a difficult for some people but take time to do this and you will be fine.



Now the core will be at an angle like shown in the picture. Give it a little twist to straighten the core on the board, it doesn't need to be perfectly in line with the screen printed inductor shape.





Now **fit L3** just the same way. We should have both inductors fitted now.

Next we can **fit the BNC connector**. This should be pushed right down onto the PCB. It has two wire connection points and two larger mounting lugs, the lugs can take some heat from your soldering iron to allow solder to flow around them, this connector will be very hot for some time afterwards so be careful not to burn yourself! When fitted be sure to trim the two wires

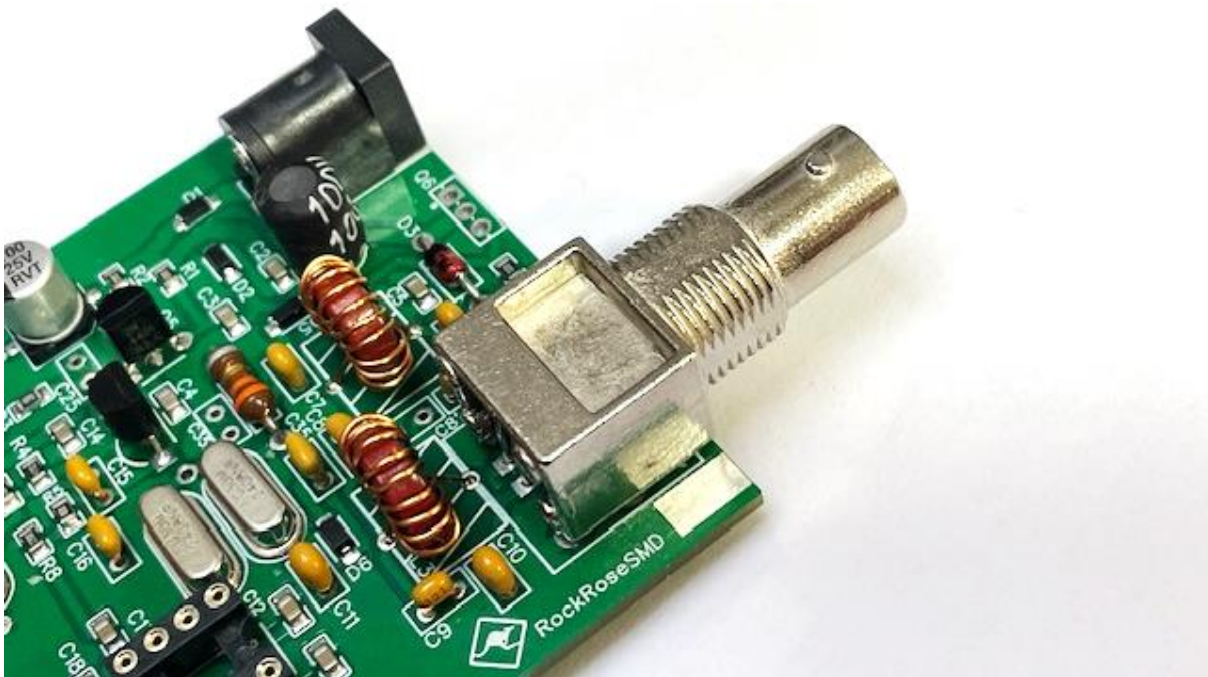

We can now do another little test. Connect headphones, key, antenna and then power.

You will hear either a 'A' or 'M' depending on what key is connected.

Now you should at least be hearing some band noise, flick the front panel switch and the reception frequency will change. We haven't done any alignment yet so don't worry too much about what frequency it's on at the moment.

Use the key and the RX should be muted and you will hear sidetone.

If that all works then we can move on.

Stage 10: Fitting the PA Transistor and rear panel.



First find the heatsink mounting pad. It should be noted that the type of transistor does NOT need a mounting bush **BUT** does still need an insulator pad so make sure you use it,

Despite saying that it doesn't need a bush it still remains the most commonly asked question, and confusion amongst many builders.

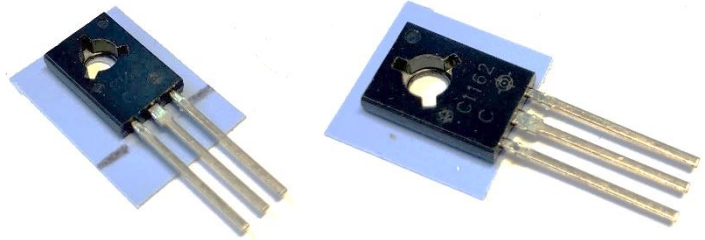

People are getting confused between the TO-220 type transistor and the TO-126 style we are using. Both need the rear of the transistor to be isolated from any metal of the case but No BUSH is required with our transistor but you **MUST** still use the insulator pad.

Cut about 3 or 4mm off the bottom of the pad.

It a good idea to **first cut down the legs a little of the transistor**, from the bottom of the transistor measure 10mm and cut the three legs off at that point. The transistor has one side with a large metal pad, this is the side that **MUST** face towards the edge of the board. Put the transistor into place on the board and tack solder **just the centre pin**. **The height from the bottom of the transistor to the top of the PCB should be 4mm**. We are only trying to hold it in place while do the physical alignment of the rear panel.

Make sure that it sits square to the board and not leaning left or right. Pass the black M3 screw through the mounting hole of the rear panel, put the thermal pad over the screw on the inside, slide the panel over the BNC and the screw through the PA transistor, use the M3 nut to secure the transistor to the rear panel, finger tighten the BNC nut to hold the panel in place. Your panel will be made from 1.6mm thick aluminium sheet and this acts as a heatsink too. Now the harder part.



It most likely that the panel isn't aligned with the hole for the DC socket. You will need to hold the board and re-melt the solder on that one pin of the PA transistor to allow you to align the rear panel correctly, make sure that the DC power plug fits now you have aligned the panel, once you're are sure all is ok you can solder all the pins for the PA transistor. Then trim the leads on the bottom of the board.

Stage 11 Alignment

Before we apply power we need to do a quick test that the PA transistor is mounted correctly. Use a test meter and check that there is no short circuit across the power connector. If there is a short then you may have not fitted the thermal pad correctly, take off the rear panel and check then refit and test again.



Connect a key/headphones/ Dummy load if you can, antenna if you can't, and power.

Start with 12v DC if you can.

Double check that the blue trimmer is fully anticlockwise! If you have one, a QRP power meter will be a great help at this stage so use that if you have it.

You need to use another radio to provide a test signal at a known frequency and also its useful to check your transmission too.

We have two variable capacitor trimmers that we will be adjusting for RX and TX frequency. I find that there is a little interaction so do this stage a couple of times to be sure.

For the alignment stage we need to be able to produce a steady carrier

To do this we would be best to use a straight key but if you only have a paddle key we can use that in a straight key mode. If using a paddle key before we power up the board press and HOLD the right-hand paddle, this will make the radio into see a straight key.

As we power up we should hear the letter 'M' which tells us it's in Manual Keying mode.

Now with the power meter /dummy load attached press the key down for a second or two, if you can monitor the current, it should be around 150-200mA. The power meter should show around 1.5 watts or lower now. If all working, we can move onto aligning the frequency.

Make sure the slide switch is slide to the left (this is important!)

Tune your main radio to 7.030MHz. you may need a length of wire or antenna connected to your main radio. Now transmit on the RockRose. You should be able to find the signal on the main radio by tuning up and down a few hundred Hertz. Now set the radio back to 7.030MHz. adjust the yellow trimmer on the RockRose to adjust its TX frequency, use a narrow filter on the main radio if you can to make it easier to set the transmitter on the right frequency. Do not keep the key pressed for more than 10 secs at a time to be sure you don't over heat the PA transistor, allow it to cool a little between key down periods.

Now you need to set the receive frequency on the RockRose. Set the main radio up with an antenna or **much better** a dummy load (we don't want to cause interference for others!)

Set the main radio to the lowest power level you can and transmit a carrier while listening on the RockRose (No Antenna should be needed on the RockRose). If you have an antenna connected check that the frequency is NOT in use and repeat this check while doing the alignment, be a good neighbour and keep the transmission short. Adjust the white trimmer now for best received signal, you will find a peak in volume around 800Hz.

Now redo this alignment again for both TX and RX.

Now check channel two, flick the switch on the RockRose and transmit again. Now retune the main receiver to find the signal, it should be approx 800 hertz higher than before. Now transmit on the main radio and you should hear the signal on the RockRose.



If all as gone right that should be finished.

Alignment can be difficult as there can be some interaction and the process may need doing a few times to get things right.

The next thing is to set the output power, decide what voltage you are going to power the RockRose from, I use a 3 cell Li-Poly rechargeable pack (3 x 3.7V cells) which when fully charged is just over 12v so I set mine at this voltage, while transmitting adjust the blue trimmer for no more than 3 Watts, in fact you should make sure you do not set the power to the max the radio will generate, if using a lower voltage that struggles to get the 3 watts back the power down a little to say 2 to 2.5 Watts. If using a 13.8v supply you may see up to 4 watts max, don't run it at this level, back the power down to 3 watts max. if you are likely to be using it on a number of different power sources then I suggest setting it up on the highest voltage you will likely use (maybe 13.8v) and not exceeding 3 watts at that voltage, you may have a little lower power then on 12v but the PA will have better protection from field day SWR issues !

If you do not have a suitable power meter we can still set the power level correctly, you will need to monitor the current the radio draws when in transmit mode. start with the blue trimmer full anticlockwise. Now while transmitting into a dummy load monitor the current as you adjust the blue trimmer. I suggest setting this to approx. 400mA @ 13.8V, if you are using a lower voltage power supply to do this test (12v) you should set the power by monitoring the current and setting it to around 320mA. Under no circumstances leave the trimmer set for max power or current, always back the trimmer off from the max level.

You may find that your RockRose can't manage the full 3 Watts, In that case you may find a power increase if you spread or squeeze together the turns on the two T37-2 cores. Past experience has shown that in cases where the power output is a little lower than expected the inductor values are higher than what they should be, often removing 1 turn from each coil can help bring the power levels back up. If you do reduce the turns only do so by 1 turn and recheck the power/current again afterwards. If you can't measure the current or power then you need to be careful, I would suggest in these circumstances to set the blue trimmer fully anti clockwise and then advance it clockwise to just over the halfway position. You can always re-adjust it at a later time when you have access to measuring equipment.

Stage 12 RX/TX Led

Only part left to fit is the RX/TX led. It is intended to be Green on RX and Red on TX, if yours ends up the other way you fitted it backwards (Leave it like that if you wish!)



Look carefully at the LED and you will see that the legs are all different length, when its



fitted the shortest leg should be nearest to the left hand side edge of the board. Fold the legs at 90 degrees 10mm from the back of the led's body.

To be sure to bend the led the right way hold the led horizontally with the body facing you, I use long nose pliers to hold

the legs 10mm from the body and bend them downwards. The shortest leg should be on YOUR left as you look at it this way.

Now put the led into place on the board, again make sure the shortest leg is nearest to the left had edge of the board with the front nearest to you.

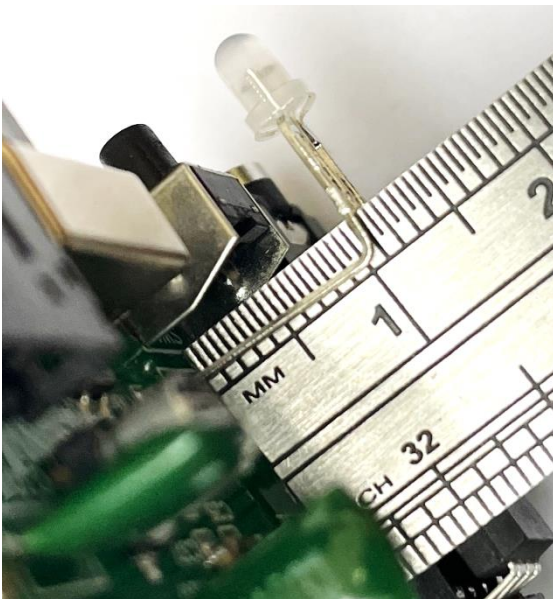

The LED should be mount approx. 11mm above the board as shown here.

Solder just the centre pin and trim the leads so there is about 2mm of legs still below the board, don't trim them flush just yet.

now slide the board into the case to check it fits and the LED pops into its hole.

If all good solder the remaining legs and trim the leads flush on the bottom of the board. If the led doesn't line up resolder and adjust the height to suit before completing the stage.

Now slide the board into the case and secure the back and front panels with the screws provided, before you do the case is intended to have the smooth side on the top and the side with the slight recessed panel should be the bottom. Don't tighten then until all screws are in place or you may find it hard to get the screws into their holes. Once done fit the 4 small stick on feet.

Congratulations you have finished the RockRose.

Make sure you have a matched antenna and connect the RockRose up with power and other leads. Give a call and see who you can work, remember that position 'A' on the front will be 7.030MHz and 'B' will be approx. 7.0308 Mhz (800 Hertz higher). If you get no reply why not check the Reverse Beacon Network to see how far your call has gone.



TOP TIP's

Give the RockRose a couple of days use and re-run the alignment again, often things seem to settle down and the frequency may be a few 10's of Hz off so a quick re-alignment can be a good idea

A question I get asked is how do I know if the station I am hearing is on the right sideband for me to work them? When listening to a calling station flick the switch to the opposite position. If the pitch goes lower (ideally zero beat) then they will most likely hear you. If the pitch goes higher then I am sorry to say they are not on the same sideband as you and will not hear you reply. This works on either channel.

Notes

All direct conversion type receivers can suffer from noise and other issues when used with a mains power supply. We recommend that the RockRose is powered by a battery pack. We have used and would recommend a 3-cell lithium-ion battery pack that gives around 11v-12v. The RockRose still produces around 2.5 watts or more at this voltage and will operate for a very long time with such a power pack. A 7Amp/Hr 12v lead acid battery is also a good choice. It is always a good idea to put a fuse in the power lead. A rating of 1 amp should be fine. Other 40m band frequencies can be used by changing the Crystals, if you are only moving by no more than couple of KHz then you will be ok just changing the mixer crystal (Y1). If more then you will need to change all three crystals to the same frequency. (The mixer crystal should have a load capacitance of about 18-20pf if you decide to try your own crystal)

Audio Filter Response

The RockRose unlike many such simple transceivers, uses an active audio filter. This makes use of the spare op-amp in the dual op-amp used in the audio amplifier. This is centred around 700Hz-800Hz and has a bandwidth of 500Hz.

The filter is certainly NOT a brickwall but does give a useful peak of about 12db to its centre frequency. Here is a waterfall showing the filters response. We used a Kanga RF Noise source module for the input to the transceiver and used a waterfall display to see the response.

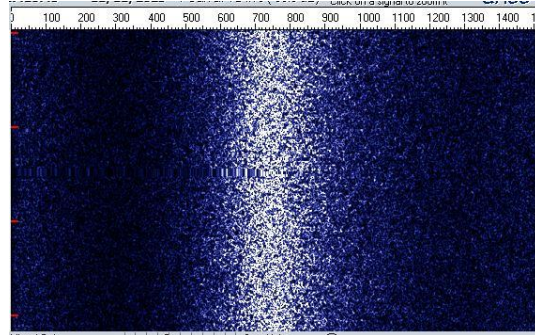

The RockRose, as you would expect, has a LPF on its output (the same one as the Rooster but with toroidal cores). We have included 2nd and 3rd Harmonic traps too. Here is an example of the RF output spectrum, this was supplied by one of the Beta builders at the RSGB Convention building the Rooster but the RockRose is using the same filter design .

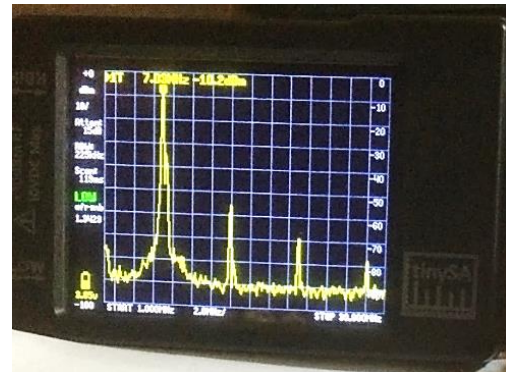
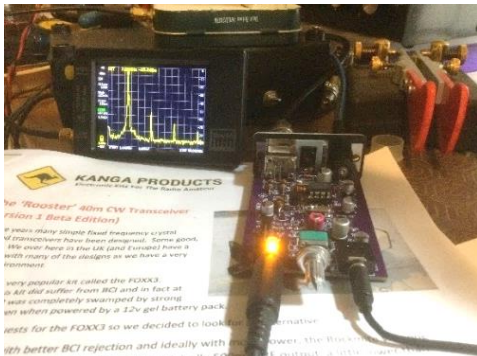

We hope you enjoy building and using the RockRose.

Any questions or comments to sales@kanga-products.co.uk



RockRose User Guide

The RockRose uses a built in keyer with a number of features you need to program.

When you complete the RockRose you can just use it as is. The keyer will be set to around 12 WPM. The push button switch at the front can just be ignored if you wish but it does give a few Software options for the keyer.

Setting the Keyer Speed

Press and HOLD the CMD (Command) Button for a few seconds and you will hear 'S' from the side tone, (This is not transmitted)

Now release the button.

Press the left paddle on the key to increase the keyer speed and the right paddle to decrease the speed, once you are happy press and release the CMD button and that will save the new speed. If you don't press the button after 8 secs the radio will return to receive and the new speed will not be stored.

Auto CQ Setting Your callsign

Now an unusual feature is the Auto CQ call feature the keyer offers. To use this you need to store your own callsign in the rig. Here's how to do that.

Press and hold the CMD button again, wait to hear the 'S' as before, BUT DO NOT release the button after a couple of seconds you will hear 'I' (For I.D) , release the button. Now using the paddle send your callsign (up to 10 characters) and then press the button again to exit. Now if you press the button and release you will transmit an Auto CQ call with the stored callsign. To cancel the auto CQ midway you need to press and hold the CMD button for over 1 sec and then release.

Two more features still to go.

The RockRose can be used with a straight key, a lmbic paddle (Mode B) and also it has a Bug emulator, the straight key is automatically detected at power up if the radio sees a mono plug in the key socket, if it sees a stereo plug (or even no plug at all) it will switch to lmbic mode. if you want to try the Bug emulator you need to select this.

To Set Bug Emulator mode

Press the CMD button and hold, you will hear a 'S' again, keep it pressed and you will hear 'I' to set the callsign, keep it pressed. You will now hear 'M' (Mode) now release the button and send a Dot with your paddle, you will hear Morse Code for 'NOR' and the radio will be in normal paddle mode, if you sent a Dash instead of the Dot the radio will reply with 'BUG'. The radio is now in Bug emulator mode.



**KANGA
PRODUCTS**

In this mode Dots will be sent as normal from the paddle but the timing for Dash is manual controlled by how long the Dash paddle is held. To get back to normal paddle operation you need to repeat the setting process but send a Dot and not a dash. Real Bug keys are NOT supported!

To Add /QRP or not to AutoCQ

The last option you can set, and some people disagree with using this but that's personal choice, is to automatically add ' /QRP ' to the end of the auto CQ calls. To do this Press the CMD button with the radio off. Keep it pressed and power on the radio. You will first hear the mode letter (as normal) that will be 'A' for normal Iambic mode, 'M' for manual straight key mode or 'B' for Bug emulator, keep the button pressed and after a couple of seconds you will hear 'QRP'. This means the /QRP will be added to your AutoCQ, if you wish to turn this off once set, repeat the process and you will hear 'NO' to let you know it will not be added.



Circuit Diagrams

DC Power Input

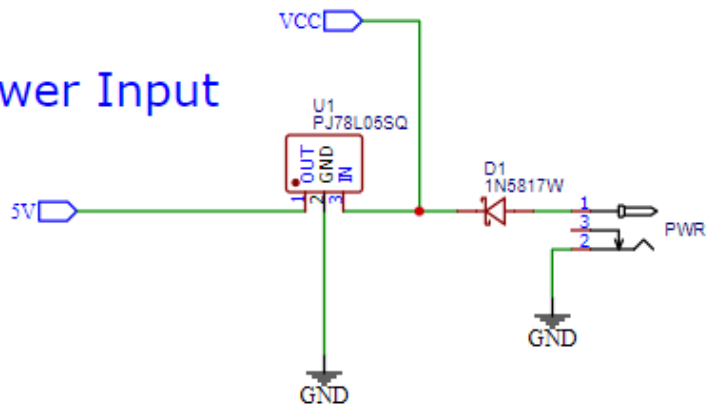

LPF/ Front End Filter

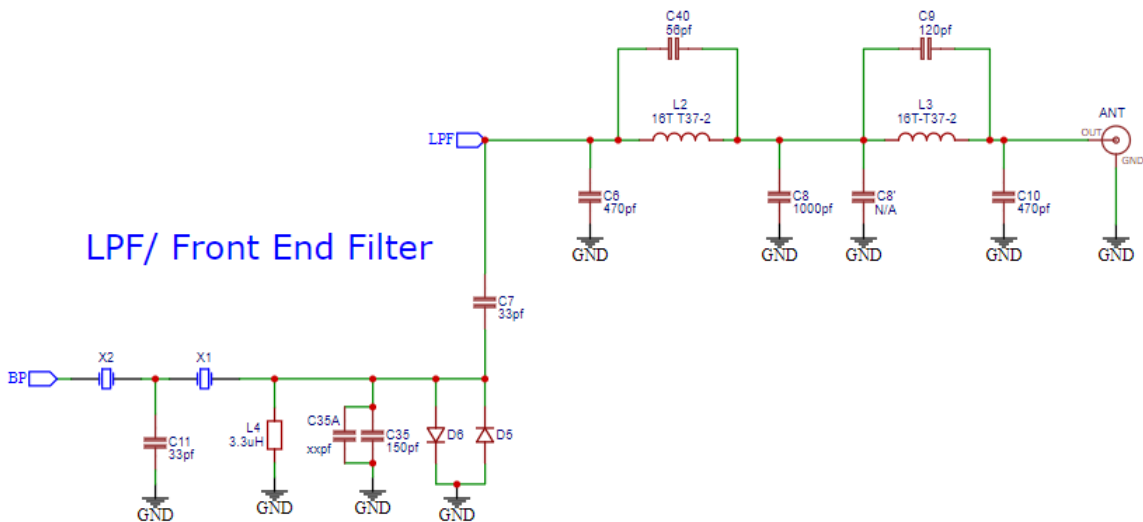



SideTone Circuit

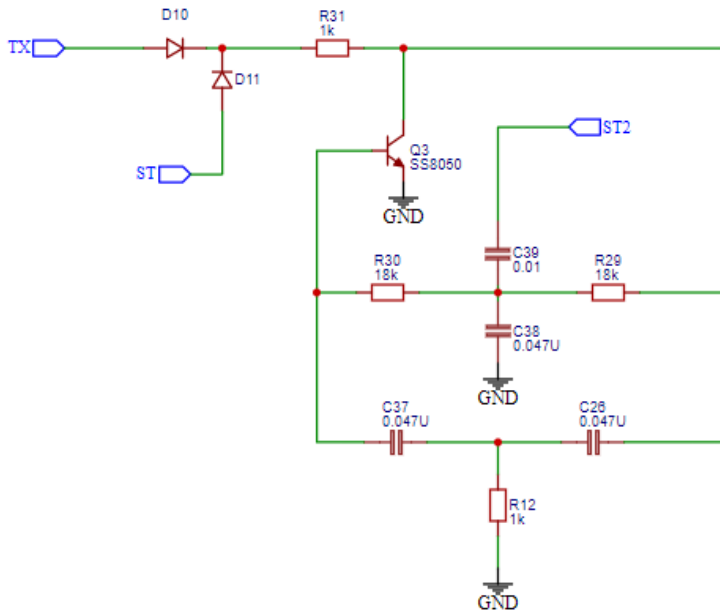

Mixer

