



**KANGA  
PRODUCTS**

# 'Rooster' CW Transceiver Kit Manual and User Guide

Rev 4 30/12/2023



Easy Build 40m Crystal controlled Transceiver.  
Direct Conversion Design  
Part Pre-installed SMD design  
Only 20 parts to fit, No coils to wind!  
Single Frequency Crystal controlled operation  
Front panel RIT control  
approx. 2 Watts RF Output  
Active Audio Filter  
Pleasant Sinewave CW Sidetone  
Visual RX/TX indicator  
10-14v DC Operation  
Supplied with Strong Aluminium Case



## Introduction

Welcome to the Rooster. The Rooster is designed to be a single evening project that will be fun to build and even more fun to use. The Rooster is intended to be a replacement for the FOXX3 kit Kanga offered for many years. The FOXX3 was very popular but had a few issues that we wanted to address with its replacement. We wanted a simple transceiver kit that offered better sensitivity and selectivity, more power and a purpose made enclosure.

The Rooster was first offered at the RSGB convention in 2023 to beta testers and following feedback the Rooster design was updated to this version.

The design is based around a standard SA/NE612 front end mixer/oscillator with an op-amp audio amplifier and active audio filter. The transmitter also shares the NE612 oscillator and buffers the VFO signal before feeding it to a high gain PA stage giving approx. 2 watts of RF.

The kit uses a mix of SMD and through hole parts, ALL the SMD parts are pre-installed but still leaving about 20 parts to fit to complete the transceiver. The kit can be completed in around an hour by an experienced builder and would be a good choice for an intermediate level build-a-thon option.

The Rooster will require a suitable antenna with a low SWR.

### ***Disclaimer***

The kit is designed to be built by Ham radio enthusiasts and in order to use the finished product you need to hold a valid ham Radio licence that permits operation on the Rooster frequency in your locality.

We offer the kit as is and do not guarantee the kit assembled by yourself can meet your local regulatory requirements, including spurious, environmental or other requirements.

## Parts Inventory

The parts are presented in a long strip of clear tubing, separated in sections. Each section covers a small number of stages in the instructions, only open the section you are working on at that time so you don't lose any parts. Start at the end with the DC connectors and 3.5mm PCB sockets.

Item	Qty	Value	Comment
Enclosure	1	Rooster Aluminium Case	Enclosure
PCB	1	Rooster PCB	SMD Parts Pre-fitted
Parts Pack Section 1			
DC PWR SKT	1	2.1mm DC Power Socket	PWR
3.5mm Jack	2	3.5 mm Stereo Type	PHONES/KEY
Capacitor	1	0.01uf MLCC Capacitor	C16
Q4	1	2N3906	Transistor Q4
Parts Pack Section 2			
XTAL	3	40m Crystal	X1, X2, X3
TRIMMER	1	4-20PF Trimmer	C26
Q5	1	2N4401	Transistor Q5
Diode	1	44V 1N4755A	D3
Parts Pack Section 3			
NE602	1	Mixer IC on adapter board	IC1
4 Way Strip Pins	2	Mixer Mounting Pin Strips	Strip Pins (may be fitted to IC1
IC Socket	1	8 way IC Socket	IC1
Parts Pack Section 4			
L1	1	100uH	See Instructions for colours
L2	1	10uH	See Instructions for colours
L3	1	1uH	See Instructions for colours
L4	1	1uH	See Instructions for colours
L5	1	3.3uH	See Instructions for colours
Parts Pack Section 5			
RIT	1	10K Potentiometer & Knob	TUNE
BNC	1	BNC Screened Socket	ANT
Thermal Pad	1	T226 Thermal Pad	Thermal Pad
Q6	1	2SC1162	Transistor Q6 PA Transistor
LED	1	Dual Colour LED	LED
Feet	4	Rubber Feet	Feet
Parts Pack Section 6			
Rooster Front Panel	1	Front Panel	Pre-drilled and printed
Rooster Rear Panel	1	Rear Panel	Aluminium Rear Panel
Parts Pack Section 7			
M3 Nut	1	M3 Black Nut	PA transistor Mounting Nut
M3 Screw	5	M3 Black Screw	Screws (Extra long one for PA)

## Important

The Rooster is a relatively easy to build transceiver BUT you need to carefully follow the instructions, do not move on a stage until you are sure that you have completed the previous stage correctly and fully. All parts must be fitted neatly and their leads trimmed flush. **I cannot stress strongly enough that unless you follow the instructions and make sure that each part is fitted correctly as indicated in these instructions you will not successfully complete the kit.**

Get familiar with the main PCB.

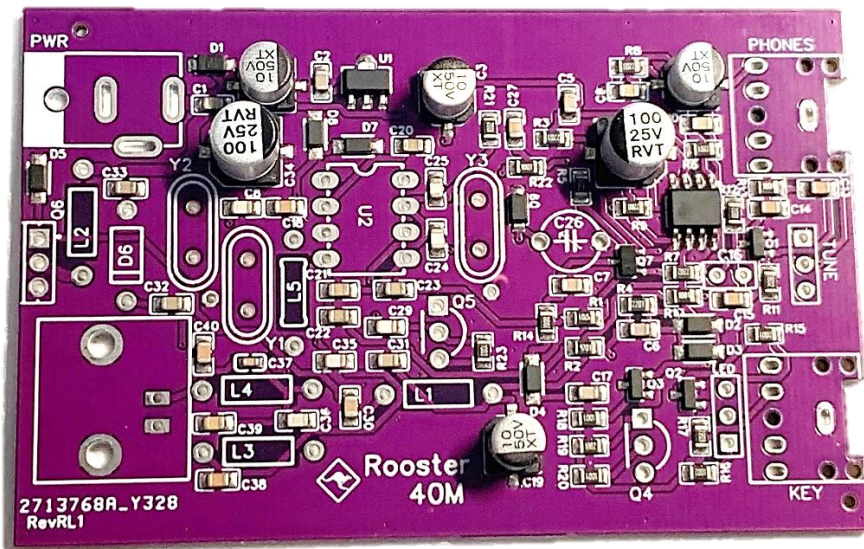

You can see many parts are pre-fitted for you, there are about 20 parts left for you to fit. Some of the parts are close together so you will need to take extra care when soldering, make sure all the parts are fitted flush to the board if the instructions call for it and trim the leads as flush to the board as you can. There is not a lot of room under the board when fitted in the case.

The parts for the kit are in a number of sections, start with section 1. That is the end with the DC and 3.5mm sockets, this will cover the first few stages of the build.

- Section 1 :- Stage 1 - 3
- Section 2 :- Stage 4 – 5
- Section 3 :- Stage 4 - 5
- Section 4 :- Stage 6
- Section 5 :- Stage 7 - 14
- Section 6 :- Stage 7 - 14
- Section 7 :- Mounting screws (Case/PA transistor)





## Stage 1 :- The DC input socket

The first part of the build is to fit the DC socket.

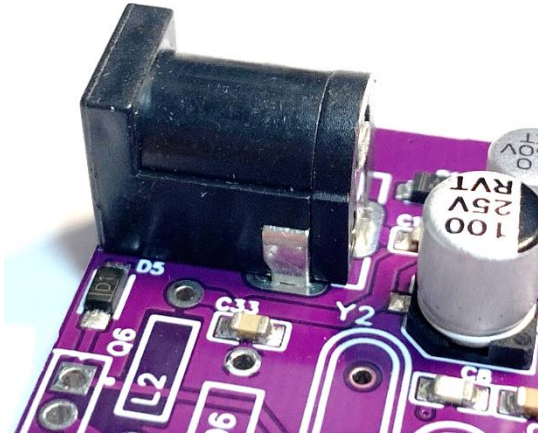

The socket must be fitted so that it's flush to the board and level with the edge of the PCB, the position for this is labelled PWR on the board. It must be square to the edge of the board as shown here. The silk screen printed layout can be used to make sure it is positioned and aligned correctly.



Solder one pin first on the bottom of the board and check the part is correctly fitted. Once you're happy that it is right, solder the remaining two other pins.

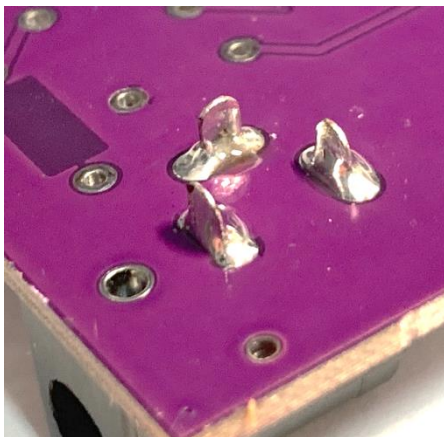

Here is what you should have now.

The 3 legs are now much too long, they would short out when fitted into the case. Use wire trimmers and cut the soldered pins flush to the board.

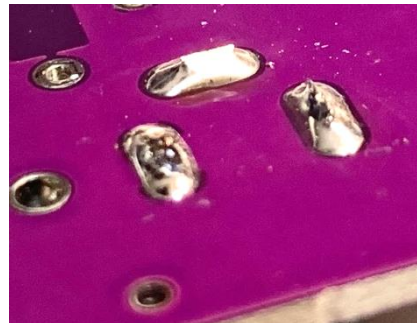

Do not move on a stage until the current stage you are working on has been completed correctly. The biggest problem identified with the beta testers was poor soldering and rushing to get the kit built. Do not take short cuts. Each part is as important as the next. Save yourself problems later by taking care at each stage.

## Testing your work

Ok we have only fitted one part but that will allow us to do some basic testing on the board.

We can test the voltage regulator and DC distribution now.

I suggest using a current limited supply if you have one and monitor the current the board draws.

For all the following test I have used a 12v DC supply.

Apply 12v to the board via a suitable power lead (Centre pin positive) to the DC input socket of the board (2.1mm plug needed)

The current consumption should be just a few milliamps, the overall finished receiver will be around 20-25mA when complete.

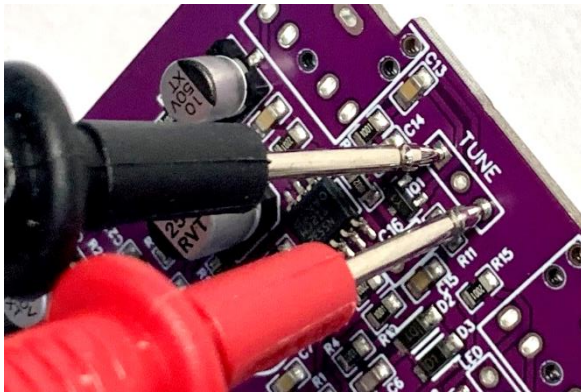

On the front edge of the board you will see the position for the RIT control (labelled Tune). Use a DC Volt meter to measure the voltage across the two outer pads for this control. You will see about 1 volt less than the supply voltage so approx. 11v with a 12v supply.

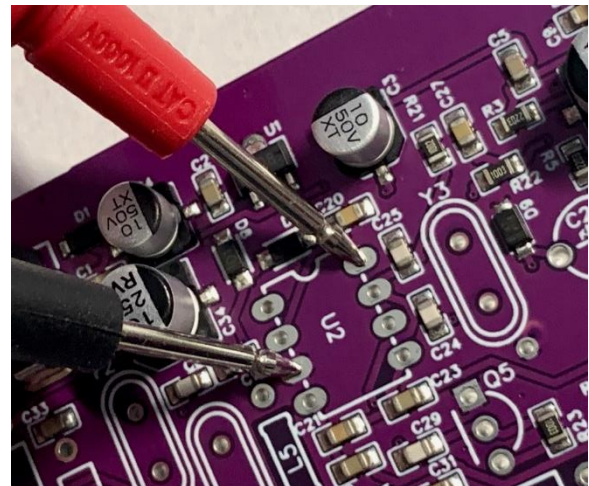

Next we can check that the voltage regulator is working correctly.

Check the voltage on position for U2 (that will be the mixer chip NE612).

Measure across Pin3 (0v) a Pin 8 (+V).

You should see 8V.

That completes the first stage and the first tests.

### Important

Now turn off the power and unplug all the leads before you move on to the next stage. After each stage of testing remember to unplug all leads from the Rooster!

Take the same care with each of the following stages.





## Stage 2 :- Phones and Key sockets

The two jack sockets are used for the key and the headphones. They fit right on the front edge of the PCB. Both sockets are the same type.

Fit them one by one. Make sure that all the pins pass through the board and none are folded over when you fit them. The socket **MUST**

be flush on the board when you fit them, if not they will not line up with the holes in the front panel later.

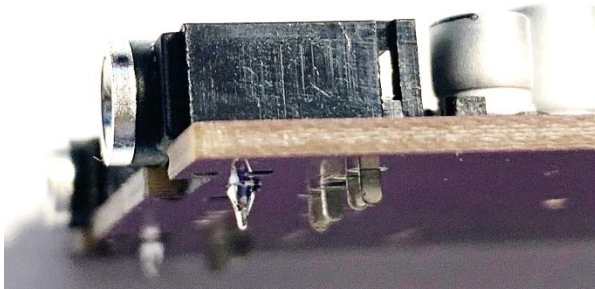
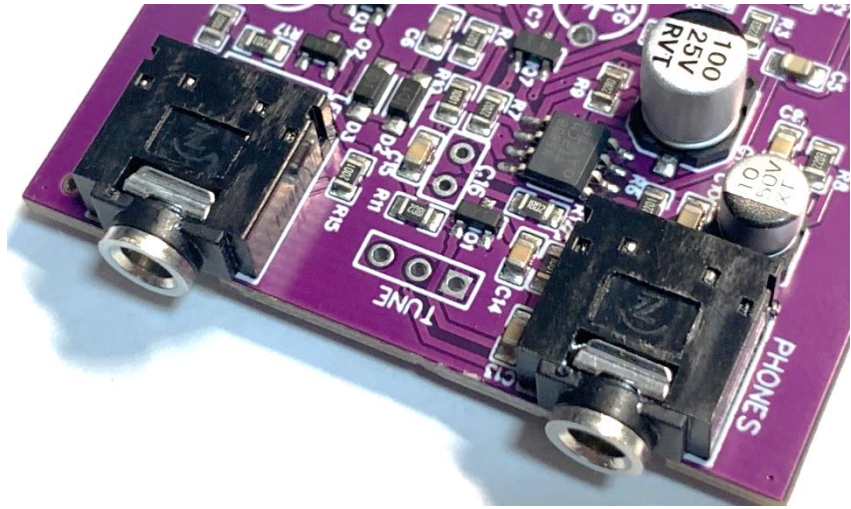

Solder just one pin on each socket first, then double check the alignment. When sure they are correctly aligned and flush, solder the remaining pins.

Again, after you finish soldering these, cut the pins flush with the board.

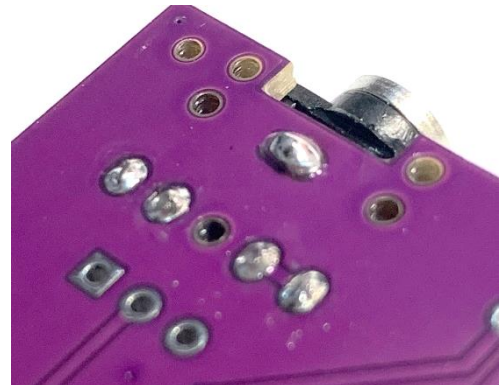

Now we can do a more interesting test on the board.

Since a lot of the parts are preinstalled we can already test the audio amplifier section.

Make sure that any off cuts are cleared from the work area.

Plug a set of **Stereo** headphones into the 'PHONES' socket and power (12v DC) up the board.

Again check that the current is less than 20mA @12v

**Please note : you MUST use stereo headphones as a mono plug will short the audio output.**



Now we can perform the 'Buzz' test

With the headphones connected, touch the board with a metal screw driver on Pin 5 of the position for U2. If you touch the shaft of the screwdriver you should hear a loud buzz in the headphones. Repeat the test but this time touch pin 4 of the U2 position

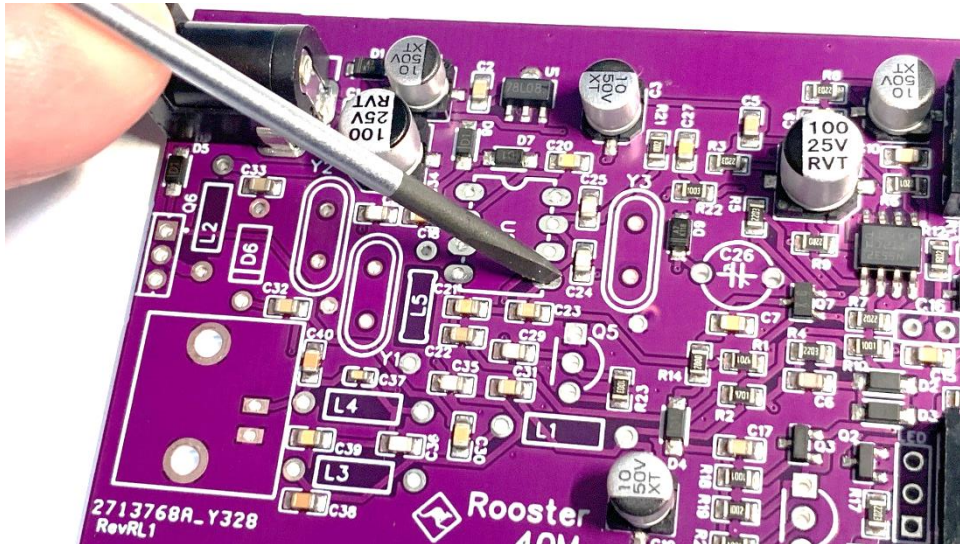

**Pin 5 Buzz Test**

**Pin 4 Buzz Test**

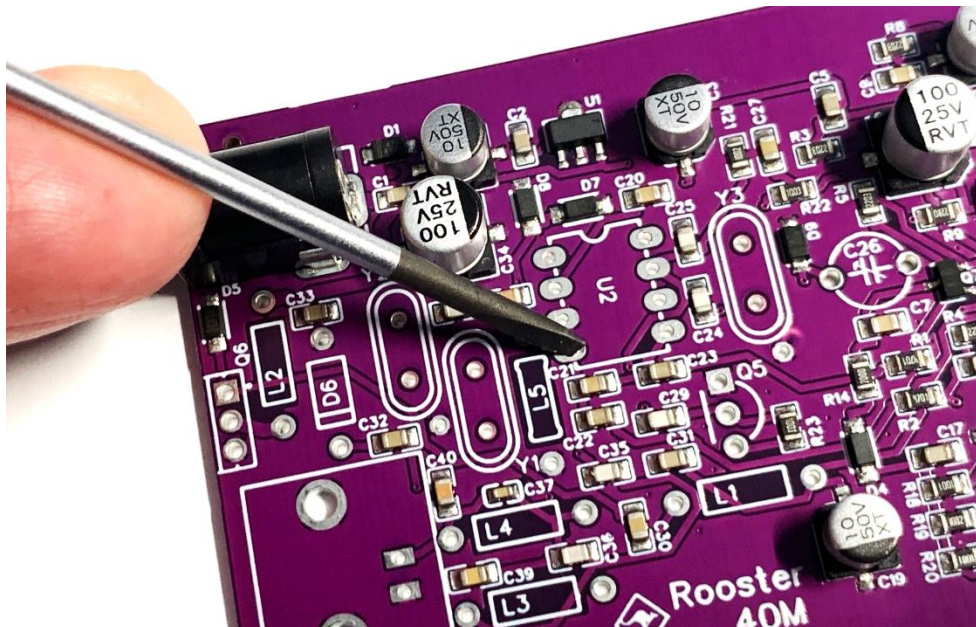

You may find that Pin 5 produces a louder Buzz than Pin 4.

This tests the audio and filter section of the board so now unplug all the leads and move to the next stage.





### Stage 3 :- Side Tone

The Rooster has a sine wave sidetone generator, much more pleasant than many radios.

The first part we need to fit is a capacitor C16

C16 is a yellow capacitor with a 2.54mm pin spacing,

The value of this capacitor will adjust the volume of the sidetone, we have used a value of 0.01uf for this.

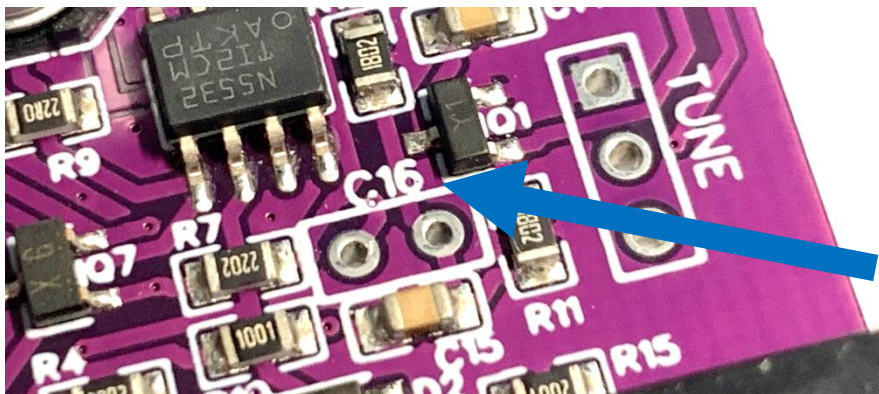

C16's position is just behind the Tune Control location near the front of the board.

Put this capacitor in its location and slightly bend the legs apart under the board, this will stop it falling out when you turn the board over to solder it. Solder one lead first and re-check it is still sat down correctly on the board. When happy solder the second leg and trim the leads flush on the board.

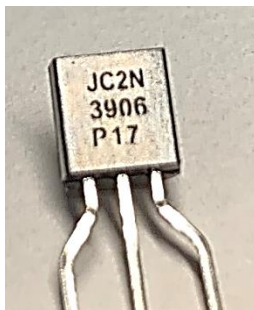

The next part is a transistor, **IMPORTANT !** many different transistors all look just the same. Look on the flat side of the transistors in this kit and check you select the right one for this, you need to find the **2N3906**.

This transistor is to be fitted in position Q4 on the board, it's just behind the KEY IN socket.

Make sure you put it the correct way round, the outline on the PCB shows the way it must be fitted.

Push the part down to the natural stop point, don't force it! It will sit about 3mm above the board. Bend the two outer legs outwards so the part doesn't fall out when you turn the board over.

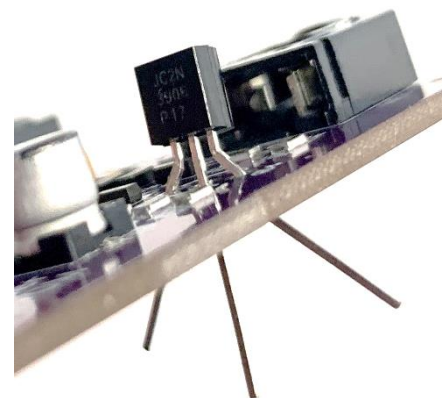



Solder the centre pin first and check the alignment of the transistor it should sit nice and square on the board. When you're happy it looks right, solder the other two pins and trim the leads flush.

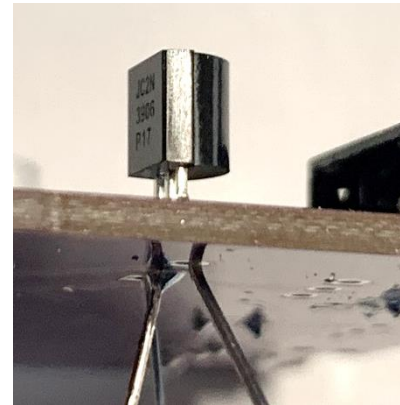
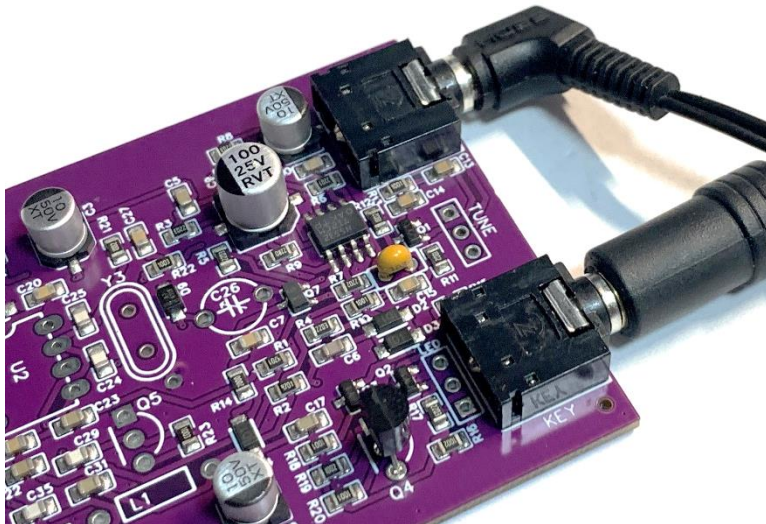

Now we can test the sidetone circuit.

Plug in the headphones and key.

Next the DC supply.

Tap the key and you should hear the sidetone. **IF** you wish you can test the muting circuit too at this time. Perform the 'Buzz' test again but while listening to the 'Buzz' tap the key. The sidetone should replace the buzz.

### Stage 4 Mixer

The Rooster uses an active mixer circuit that has much better performance than the old FOXX3 ever could offer. We need to fit the 8 pin socket for this chip.

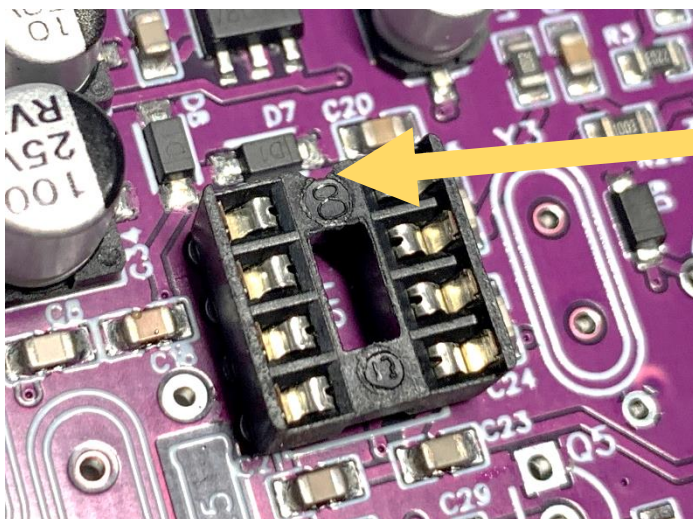

The socket, if you look carefully, has a small notch on one of its shorter edges. This notch must be next to D7 on the PCB. Make sure that the socket is flush down on the board. I solder one pin first and double check before soldering the other pins.





Next we need to fit the trimmer capacitor. Its colour may not be as shown in the photos here (if you not reading black and white paper instructions!)

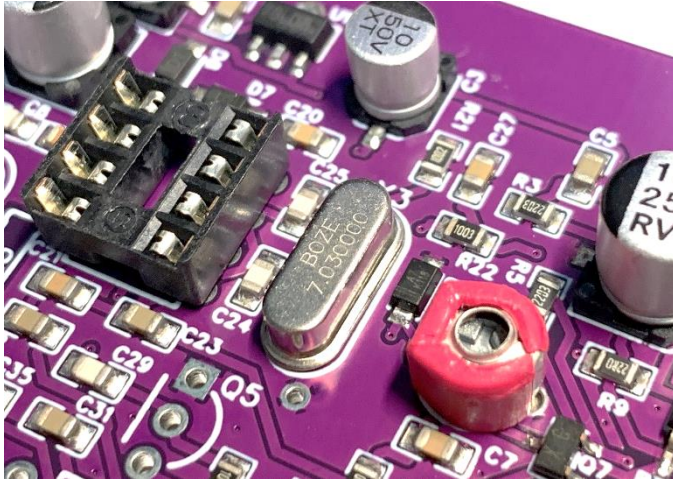

Important! The trimmer has one flat edge, that should be positioned next to the crystal as shown here. Don't worry, you haven't missed fitting the crystal, we will do that next.

### The Crystals.

The kit uses three crystals, two in the front-end filter and one for the mixer. The crystals are all the same frequency but some of the characteristics are different between the two types you have with the kit. You MAY get a set of three crystals all the same size, in that case one will have a coloured mark across the top. This coloured crystal is to be used for the mixer stage. If the crystals are supplied with two tall ones and a short one then the short one is used in the mixer.

This mixer crystal is to be fitted between the chip socket and the trimmer as shown above.



### The Mixer IC

The mixer chip used on the Rooster is getting very rare in its DIP format, but it's still available in its SMD size.

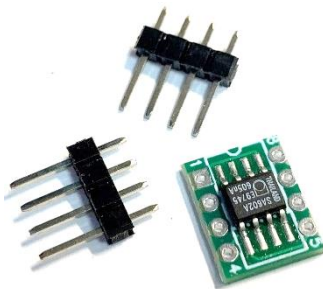

I have supplied this chip pre-fitted to a small adapter board. This assemble can be treated as a DIP chip now. Just be sure you check which end is Pin 1 (marked on the adapter board).

CAREFULLY plug the board into the socket on the board.



## RF Noise Test

Now make sure that the chip is plugged in the socket the correct way round, it didn't matter when you soldered the adapter board and pins but it DOES matter now!

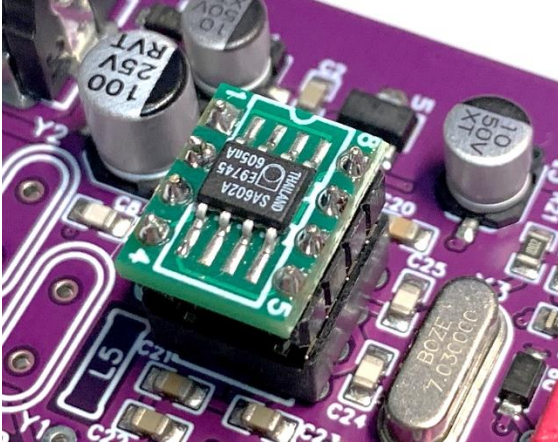

The adapter board has Pin1, 4, 5, and 8 marked. Make sure Pin 1 is nearest to the DC in socket.

Connect up the headphones/key and power again as before. Now use a metal screw driver and touch the top pin for the Y2 crystal. You should hear a mix of Hum and RF noise, you may even hear some weak CW signals! Don't forget to remove the leads after this test!

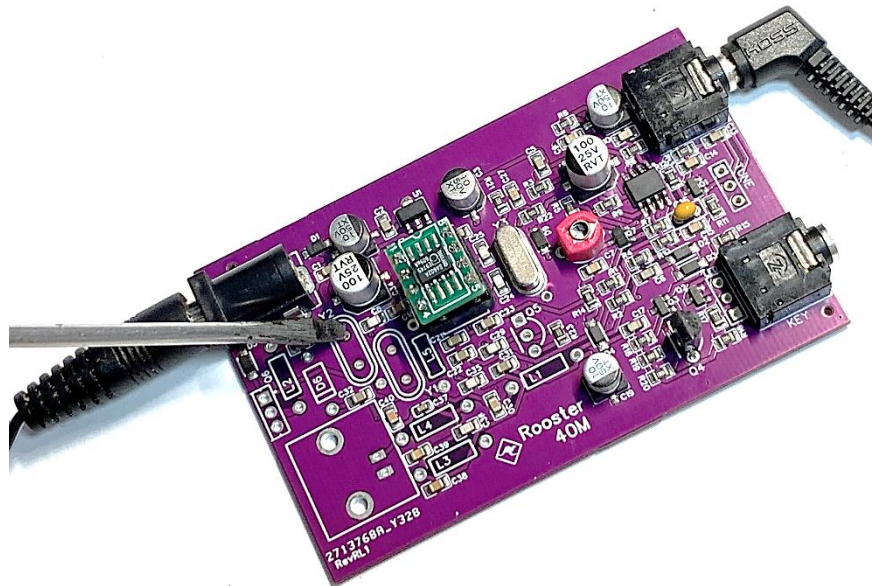

## Stage 5: Driver and PA Protection Diode

You may want to unplug the chip so you don't damage it while fitting the remaining parts.

Now fit Q5 transistor, make sure it is the right one, it should be a 2N4401. Check the printing on the flat of the transistor. And fit it as you did for Q4 before.

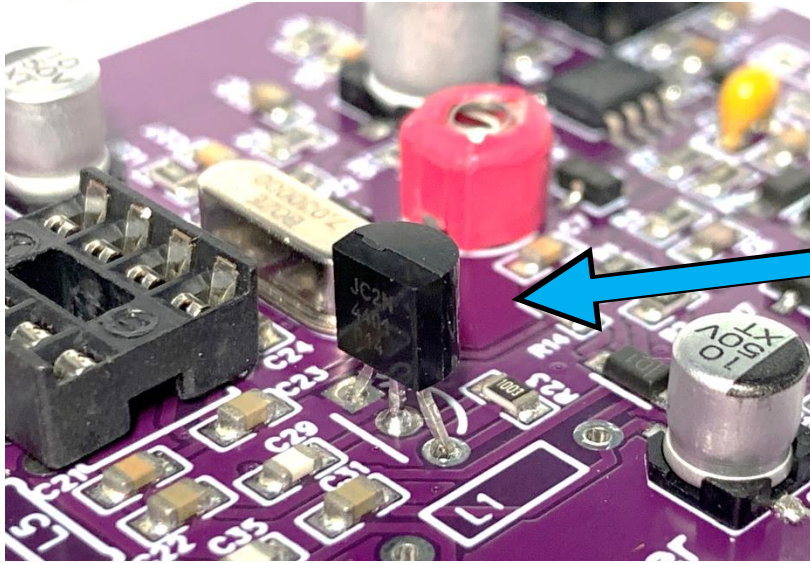

Make sure it is fitted to match the outline on the PCB and that it is sat squarely as per the picture here.

We now will fit a protection diode that will help protect the PA from high SWR. This is D6 (1N4755A).

Shape this diode ready to fit first.

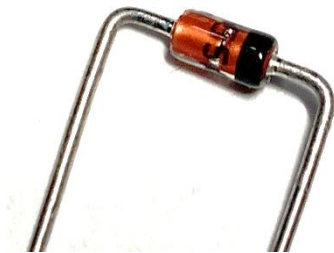

Bend the leads about 3mm from the body. Take care doing this. The diode has a glass body and you could break it if you're too rough.

You will note that this diode has a black band on one side, this is VERY important.

The diode must be fitted so that the band is in line with the line on the symbol on the PCB for D6.

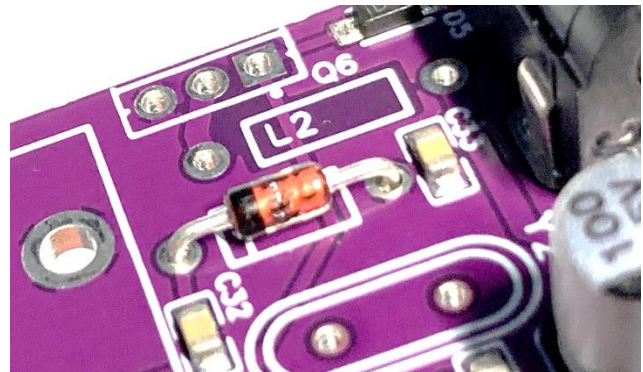



## Stage 6: Fitting the 5 inductors

This stage is the easiest to make a mistake with so read and then re-read this section **before** you fit any.

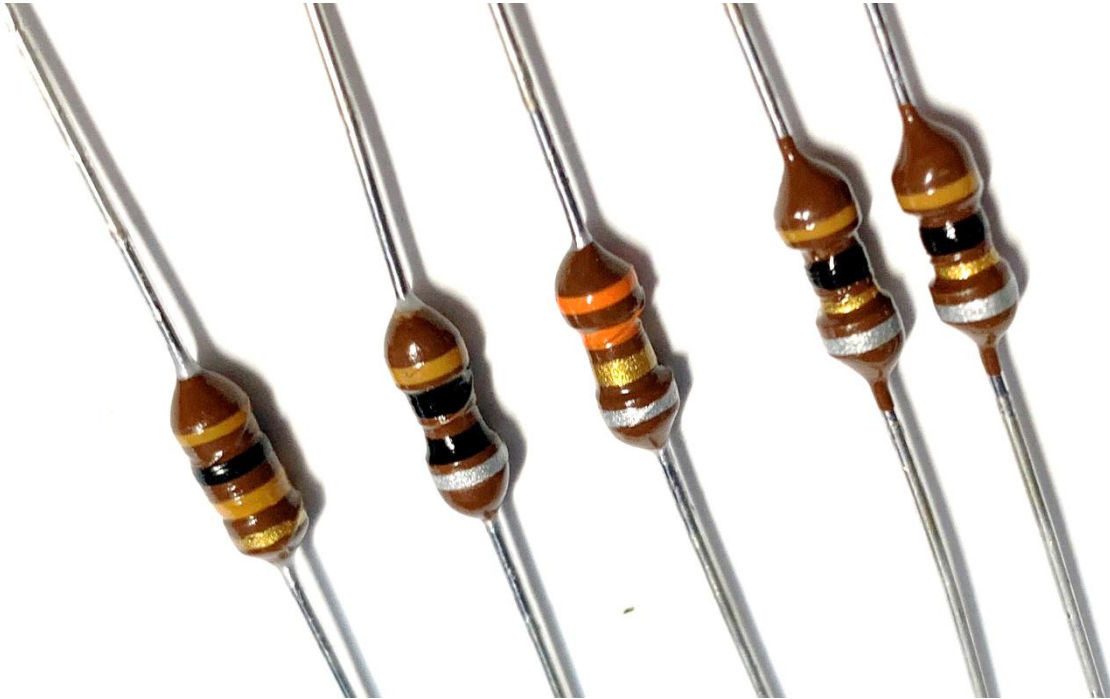

There are 5 inductors and unfortunately most are very similar in colour bands.

We need to be 100% sure that the right one is used in the right place.

Take time and care with this stage, it is hard to remove parts once fitted.

L1 is a 100uH inductor

The inductors used on this kit use the same colour bands as resistors to identify their value so you can use the colour resistor code chart that came with the kit to help you.

Don't fit any yet, let's just check the values.

L1 has bands that are Brown, Black, Brown and the last one is Gold.

L2 is a 10uH inductor

L2 bands are Brown, Black, Black, Silver.

L3 and L4 are both the same value 1uH

L3 and L4 bands are Brown, Black, Gold, Silver

L5 is a 3.3uH inductor

L5 is easy to spot, its bands are Orange, Orange, Gold, Silver.





Now you know the values read this section again and this time fit each inductor one by one.

To fit them you will need to bend the leads of each inductor at 90 degrees **right next to the body** as shown here. They will then fit correctly on the board.



Here are the inductors fitted to the board.

Make sure yours are fitted flush to the board and that the leads are trimmed flush on the back of the board.

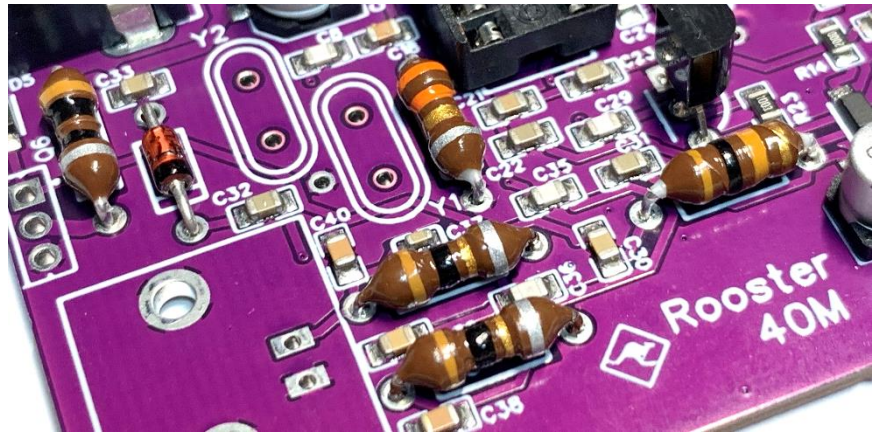

### **Stage 7: Front end bandpass filter**

We now will fit the last two crystals, Y1 and Y2

These crystals will be the larger ones in the kit. (or the standard un-coloured ones we talked about in stage 5)

They are both the same and either can be fitted in either position.



When fitted the board should look like this.

Not much more to do now.



## Stage 8: RIT Control

The RIT tune control.

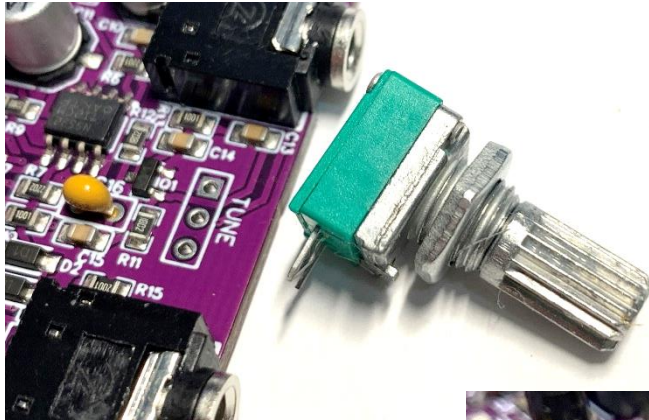

First remove the nut and washer from the front of the control, make sure the 3 pins are not bent over and insert it onto the board. Push the control down so the body is flush to the board. It must be flush to the board or the front panel will not fit!

Solder the centre pin first and check the control is still positioned correctly, when happy solder the two outer pins. Trim the leads flush with the board.

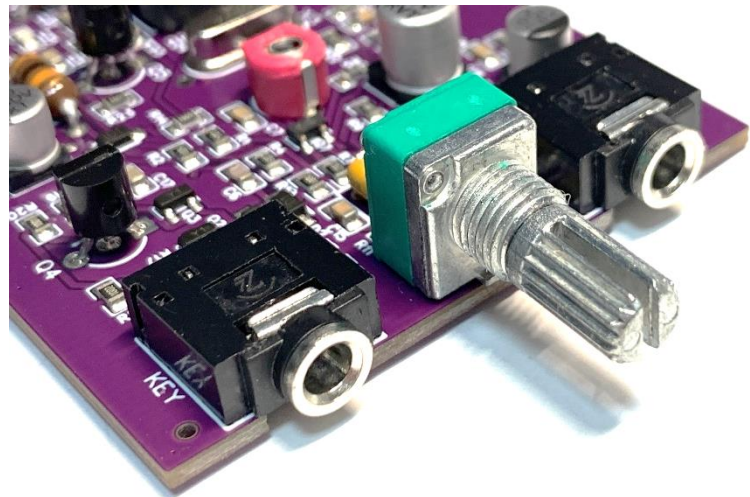

## Stage 9: Antenna BNC Socket

Now the final part, maybe the hardest to solder!

The Antenna BNC socket

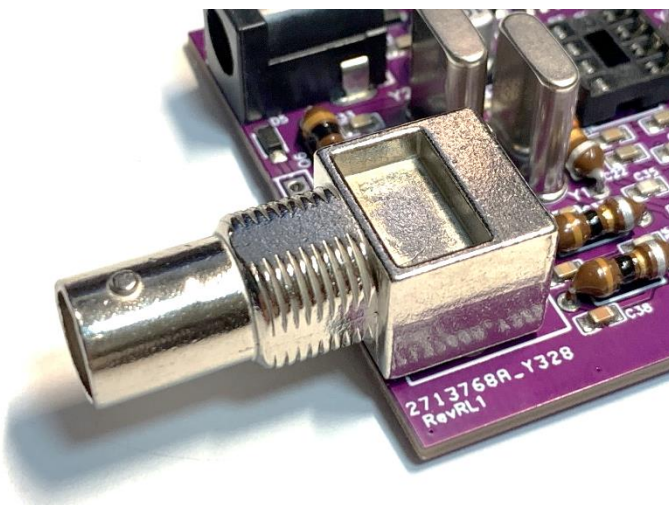

The antenna socket is a heavy item, it is made from metal and is really a big heatsink. It can be difficult to solder the mounting lugs to the PCB if the soldering iron is not very powerful. You may need to keep the iron on the lugs for a prolonged time when soldering so be very careful that you don't burn yourself on the body of it. It will be very hot for a while after you finish soldering.

Make sure that the two circuit pins pass through the PCB first and solder these before the two big mounting lugs. Trim these two leads. Press and hold down the connector flush to the board and tack solder one of the lugs. Check it's flush, if not re-melt



the solder again on the lug and reposition. When happy solder the other lug and then solder the tacked lug fully. Again, be careful this will be hot for some time afterwards.

## **Stage 10: Testing and Alignment**

Time for some testing and alignment.

If you removed the mixer chip earlier for safety now is the time to replace it.

Please understand something important now. This radio is intended to be used in the QRP area of 40m. the COA (Centre of Activity) on 40m is 7.030MHz, you do not need to worry about being bang on 7.030Mhz, there is nothing magical going to happen if you're sat on that spot frequency. I have considered swapping the crystals in the set to 1 or 2 KHz off the COA to reduce congestion in that area. The crystal supplied will not give you that much adjustment but if you find yourself one of two hundred hertz off the 'spot' don't worry, be happy! I do have crystals that will put your transmission around 7.0293Mhz which work great at avoiding all the madness on the COA and so result in a better QSO rate. Let me know if you want one for the mixer (the front end can remain the same for this small change) For the rest of the testing I will use 7.030Mhz as the target frequency.

Like all the tests so far, I would recommend a current limited power supply. Up to now you could expect a max current of 25mA, now you will need to set the limit up a little to 100mA as we have the driver stage installed and will be testing the transmit chain.

For this test you need another transceiver, antenna, dummy load (advisable), headphones and key.

Connect the remote transceiver up to an antenna or even just a short (1m length) wire will do fine.

Monitor 7.030Mhz on the remote set. Select a wide filter BUT be sure you put the radio in CW mode (Important!)

Connect the Rooster to the power supply with the key, antenna and headphones connected.

You should now hear at least band noise. If anyone is operating around the Rooster's freq you will most likely hear them too.

This is a direct conversion receiver, this means the internal oscillator runs at the frequency it is receiving, the side effect of this is that the oscillator's signal can be heard on a receiver placed near it. If you can hear a tone on the remote rig don't worry, that's normal and not a fault.

Now key the Rooster, you should expect the current to increase to about 60-80mA. Tune the remote radio to find the signal as you key, it maybe a few 100Hz off either direction.

Once you have found it retune the remote radio to 7.030Mhz





Now ideally a ceramic trimmer ( I use a small flat blade screwdriver myself, with care ! ) adjust the trimmer on the Roosters PCB while holding down the key.

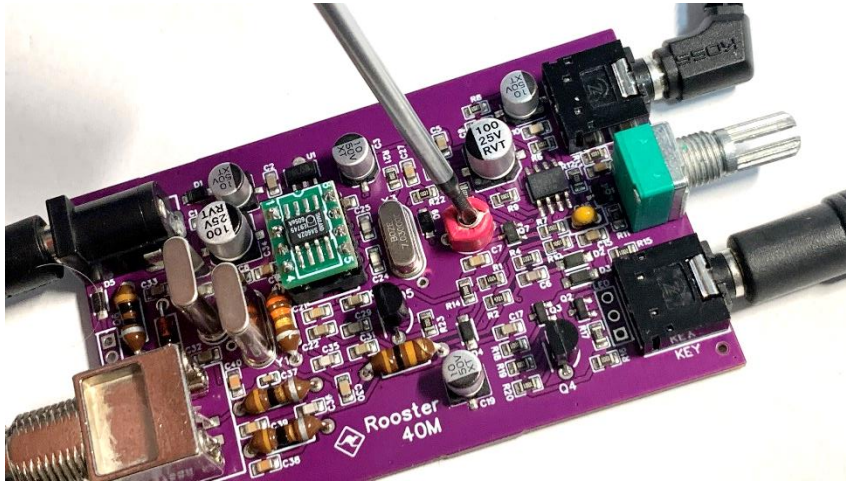

You should be able to bring the Rooster onto, or very close to 7.030Mhz on the remote radio.

The tuning will move slightly when we fit the PA transistor later as the loading on the oscillator will change but for now this will be ok.

Now connect the remote rig to a dummy load, no need for an antenna on the Rooster, transmit a CW signal on the remote rig (set the power level as low as you can).

Set the RIT control about half way and the Rooster should be hearing the transmitter, adjust the RIT control clockwise and the pitch should change, it should go very low as the control is almost fully clockwise, ideally a point should be heard when the tone stops altogether. This point is zero beat. The RIT control will have very little effect left of centre position as the adjustment is not linear.

Congratulations if this is all working, apart from the PA transistor and the RX/TX LED the Rooster PCB is complete. Again unplug all the leads and move on.

**Stage 11: Fitting the PA Transistor and rear panel.**

First find the heatsink mounting pad. It should be noted that the type of transistor does NOT need a mounting bush BUT does still need an insulator pad so make sure you use it,

Cut about 3 or 4mm off the bottom of the pad. Before you fit the pad put a small amount of clear tape on the top edge of the pad, use that to hold it in place. Put the pad on the inside of the rear panel so the mounting hole in the



pad is in line with the mounting

hole on the panel.

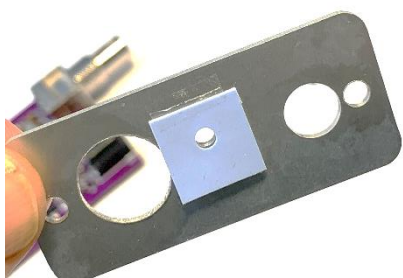

Now fit the rear panel on the back of the PCB, for now use the larger BNC nut and tighten the rear panel to the board.

Only tighten finger tight for now, drop the transistor in place so **the metal side of the transistor is against the insulator pad,**



pass the M3 Black bolt through the rear panel and through the hole in the transistors body and use the M3 nut to attach the transistor. Do not fully tighten the nut yet.

Align the rear panel so the DC connector is in the centre of the power hole in the rear panel, carefully solder the centre pin of the PA transistor and recheck the correct fitting of the panel, resolder that transistor pin if you need to make adjustments. Once happy solder the remaining two pins of the transistor and trim the leads. Tighten the BNC and the transistor screw.



### Stage 12: TX/RX LED

The Rooster has a LED indicator for RX and TX, we have used a dual colour LED so on RX it is Green and on TX its Red.

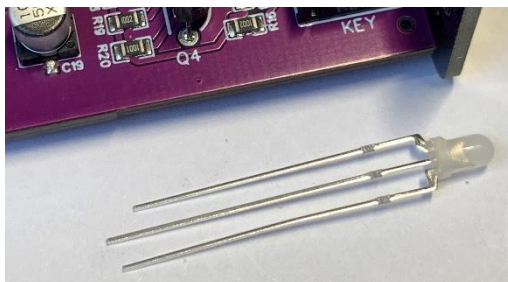

This LED has three legs, each one is a different length.

When we fit this part, the shortest leg **MUST** be towards the centre of the board.

You need to bend the legs at approx. 13mm from the back edge of the LED's body. You want to produce a 90-degree bend. I use a



pair of pliers to hold the 3 legs and make the bend. You must make sure that you bend it the right way so that when fitted the shortest leg is towards the centre of the board.

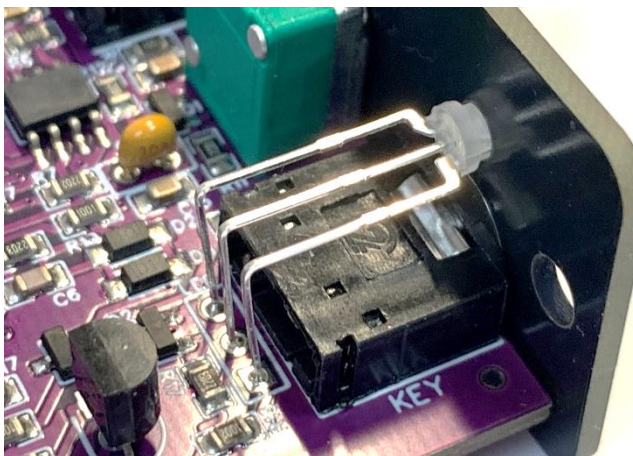

Temporarily attach the front panel loosely to the board using the RIT controls nut. Put the LED in the board (again checking the shortest pin is towards the board's centre). Then make sure the led passes through its hole in the panel. Now you have it at the correct height solder its legs and after double checking all is correct trim the leads flush. Now remove the front panel.



### **Stage 13: Tidy up the PCB**

Now fit the front panel to the case using two black M3 screws. Check the panel is correctly aligned on the case. Do not fully tighten the panel just yet.

Now before you put the board into the case a **VERY IMPORTANT** job.

Trim all the leads on the back of the board as flush as you can, there is not much clearance in the case, the 2 large lugs on the BNC are as low as you can go, make sure ALL other parts are cut flush and are shorter than these pins.

Now double check all the soldering. If you're happy you can Align the Rooster.

### **Stage 14: Alignment**

If you did the Alignment as suggested earlier this will be easy, it's just a final adjustment.

The trimmer capacitor will allow you to correct the transmission frequency, you will need a receiver to do this (or a freq counter etc)

I put a ham band receiver on 40m 7.030Mhz and in CW mode. I set the filter on the receiver, if it has one to around 500Hz.

Now connect headphones/key and dummy load to the Rooster and once all these are connected then connect a power supply. If possible, a power supply of say 11v (don't go below 10.5v) will be kinder to the PA while doing the alignment.

Key the Rooster and you should get sidetone in headphones. You should find the Roosters signal on the receiver within a few 100hz of 7.030Mhz.

Set the receiver to 7.030 and adjust the trimmer to correct the frequency. You MAY not be able to bring the frequency bang on 7.030, you may only get within a few hundred Hertz of that target. That depends on the Crystal in such a simple circuit as the Rooster but remember 7.030Mhz isn't a magical frequency, it's just the centre of operation for QRP users. Just get as close to it as you can and don't worry. Don't leave the key down for more than 10 secs at a time and give it a short break between transmissions to allow the PA to cool. Now unplug the power and leads.

Now you can drop the board into the case and the controls should pass through the holes in the front panel. You may have to 'jiggle' the front panel just a little to align it with the board. Secure the rear panel now with two black M3 screws.

Fix the RIT control with the supplied washer and nut, finger tight will be ok. Turn the control fully anticlockwise and push the knob onto the shaft so the knob's marker line is pointing just before the start of the RIT marker scale. Do this lightly first and check it looks right when you turn it full travel both ways, when happy push the knob firmly down then fit the four stick on feet.

If you have a power meter connect that between the dummy load and the Rooster, check the output power. The lowest voltage the Rooster will work on is about 10.5v, the voltage regulator (it's a 8v device) will drop out around 10v as it needs about 2 volts head room. With approx 11v you will see over 1 watt, at about 12v nearly 2 watts, with a 13.8v supply you will most likely see a shade over 2 watts, again this will depend on a few factors but a variation of a few hundred milliwatts could be



seen between units. This variation will only be 1dB or so and will not be noticeable to anyone receiving your signal.

Current draw will be around 20mA on RX, and 400mA TX (@12v)

Now connect the Rooster to an antenna. If nothing else you will hear band noise.

Adjust the RIT to about the 2 O'clock position and call CQ, if called back adjust the RIT for best reception and enjoy the QSO. Note the RIT control does not change the TX frequency just the receive frequency

### Notes

All direct conversion type receivers can suffer from noise and other issues when used with a mains power supply. We recommend that the Rooster is powered by a battery pack. We have used and would recommend a 3-cell lithium-ion battery pack that gives just over 11v. The Rooster still produces around 1.5 watts at this voltage and will operate for a very long time with such a power pack. A 7Amp/Hr 12v lead acid battery is also a good choice. It is always a good idea to put a fuse in the power lead. A rating between 1 and 2 amps should be fine.

Other 40m band frequencies can be used by changing the Crystals, if you are only moving by a couple of KHz then you will be ok just changing the mixer crystal (Y1). If more then you will need to change all three crystals to the same frequency.

### Audio Filter Response

The Rooster unlike many such simple transceivers, uses an active audio filter. This makes use of the spare op-amp in the dual op-amp used in the audio amplifier. This is centred around 700Hz and has a bandwidth of 500Hz.

The filter is certainly NOT a brickwall but does give a useful peak of about 12db to its centre frequency. Here is a waterfall showing the filters response. We used a Kanga RF Noise source module for the input to the transceiver and used a waterfall display to see the response.

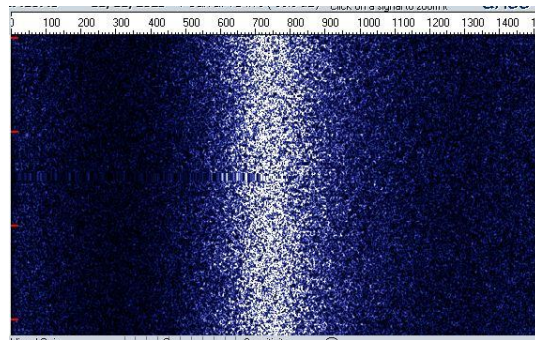

The Rooster, as you would expect, has a LPF on its output. We have included 2<sup>nd</sup> and 3<sup>rd</sup> Harmonic traps too. Here is an example of the RF output spectrum, this was supplied by one of the Beta builders at the RSGB Convention. The 2<sup>nd</sup> harmonic is at about -46dB, the 3<sup>rd</sup> about -60dB

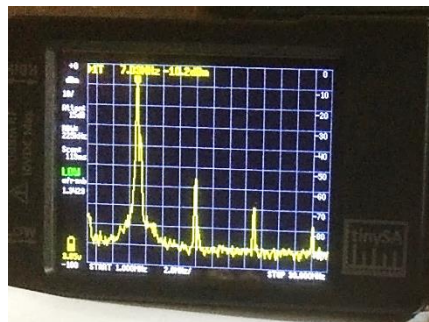
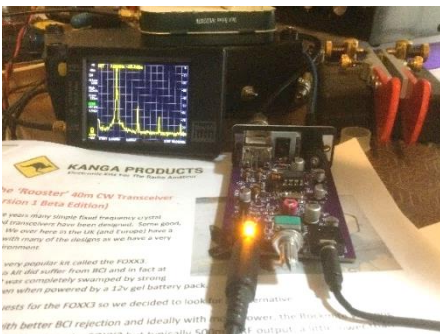

We hope you enjoy building and using the Rooster. Any questions or comments to [sales@kanga-products.co.uk](mailto:sales@kanga-products.co.uk)



# Circuit Diagrams

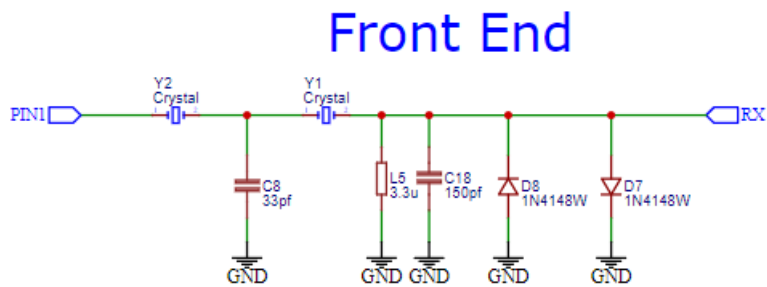
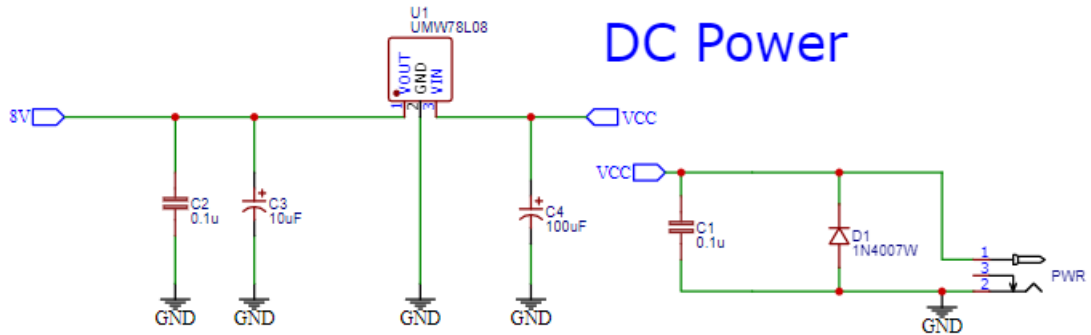

### SideTone Circuit

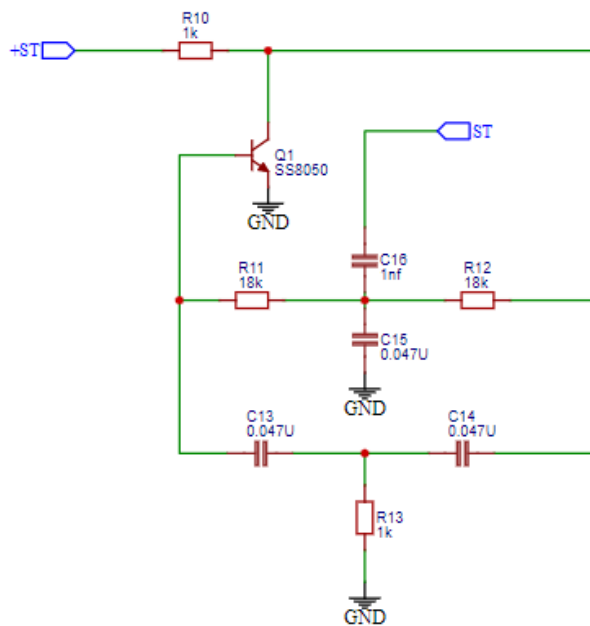



## MIXER

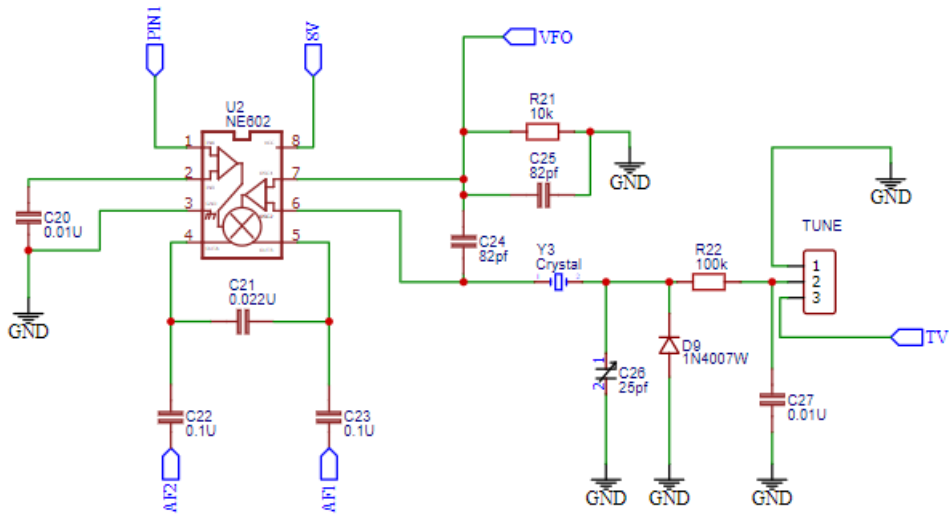

## AF STAGE

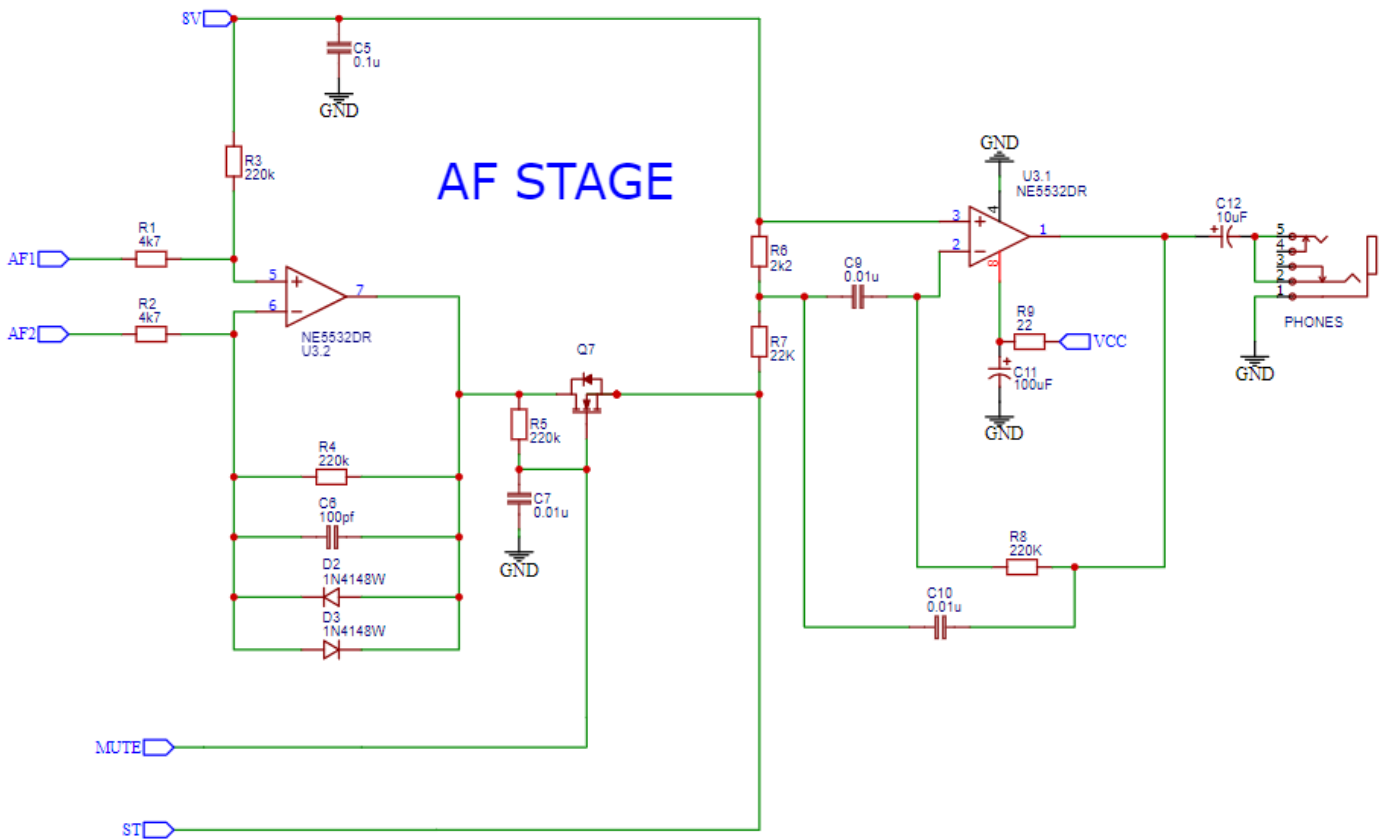





### RX/TX SWITCHING

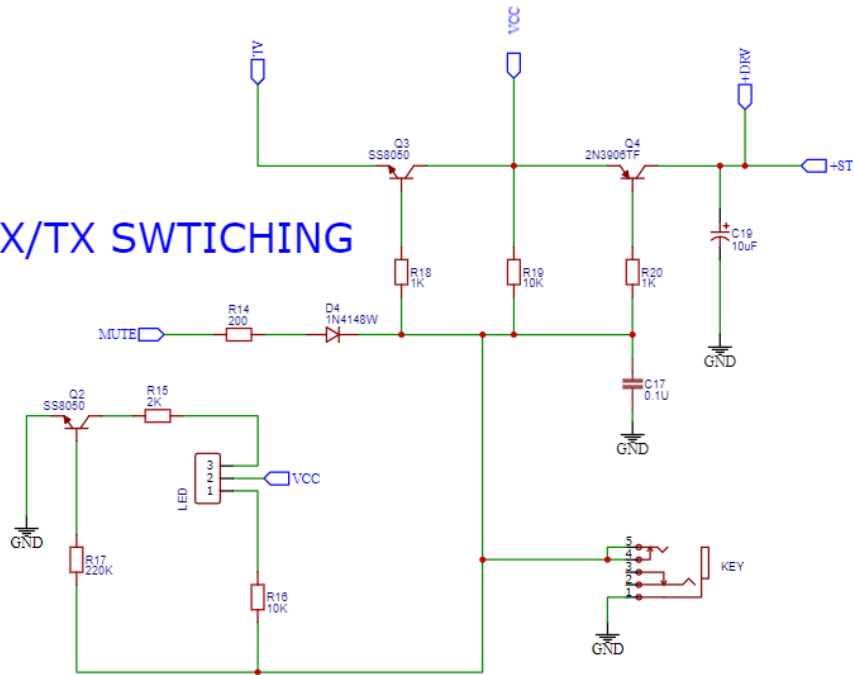

### DRIVER/PA AND LPF

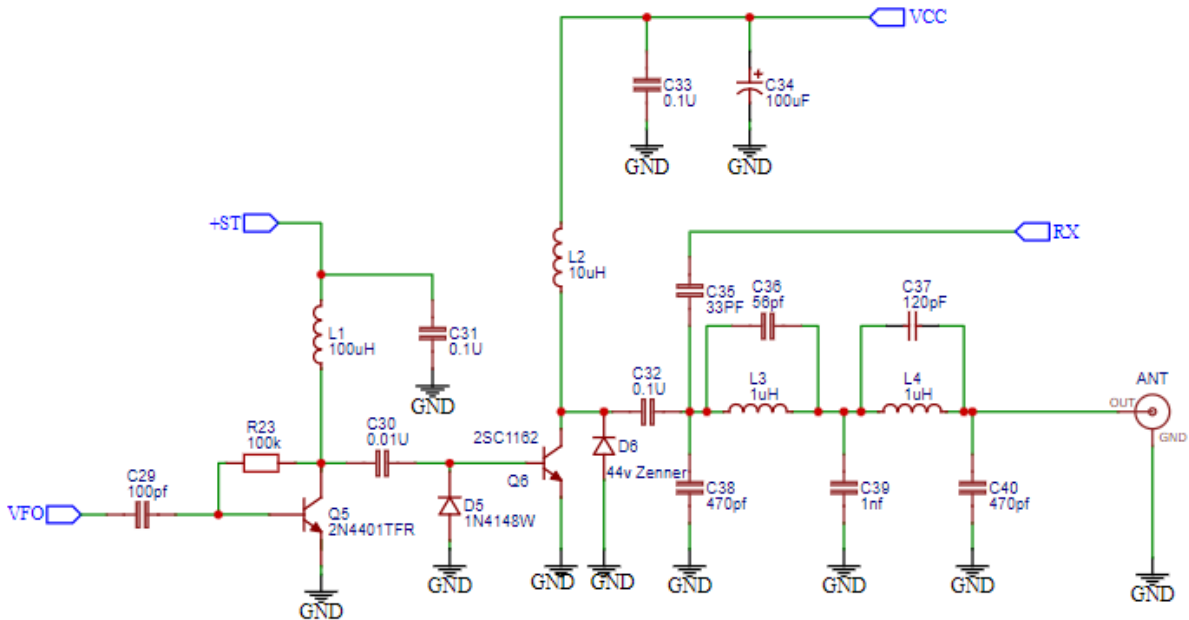



# Board Layout

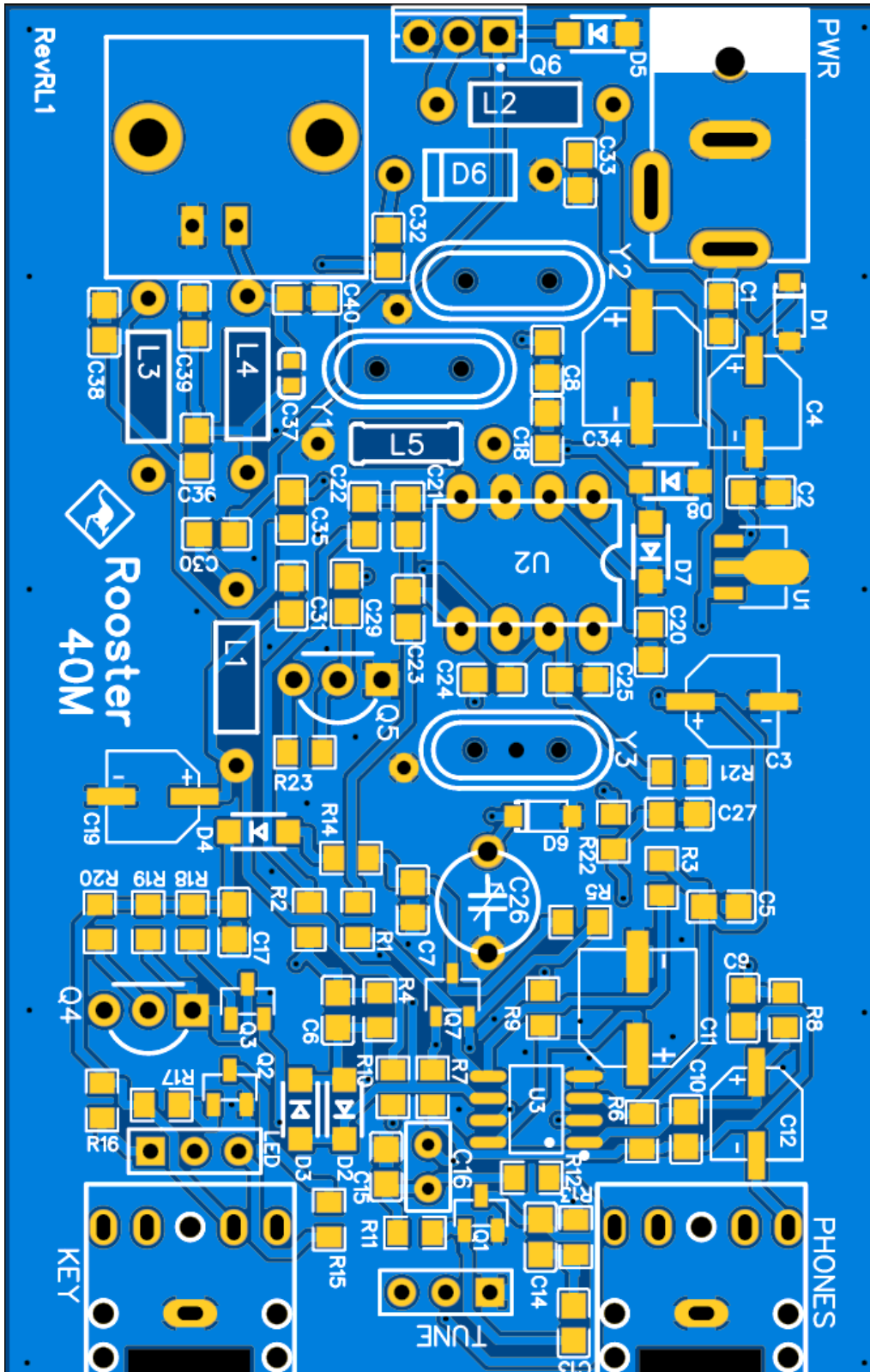



## Notes

If you don't like using headphones, then the audio output can be fed to a small audio amplifier, I use the Kanga Desktop Bench amplifier for this as its fully self-contained and works perfectly with the Rooster. It also gives the benefit of a volume control too.

Always use an Antenna with a low SWR. Simple antennas like an end fed half wave are a great choice to use with the Rooster.

All DC receivers can suffer Hum and other problems that are due to RF getting into the supply and modulating the DC to the receiver. Using a DC battery pack generally cures these issues completely. A good choice is a radio-controlled car racing pack of 3 x 3.7v cells. These are typically 3-5 Amp/hr packs and will power the Rooster with easy for a number of days of heavy use.

### **Sidetone volume problems?**

The volume of the sidetone can be changed by altering the value of C16, the standard value is 0.01uf (10nF), for most this will be ok. If you like a lower volume for the sidetone then change this for a lower value maybe 1nf, if you want it louder try 0.1uf (100nF).

---

---

---

---

---

---

---

---

---

---

---

---

---

---

---

---

---

---

---

---

---

---

---

---

---